



CATÁLOGO 2022

CATALOGUE / KATALOG

MOSQUITERAS

INSECT SCREEN / MOUSTIQUAIRES / INSEKTENSCHUTZ



MOSQUISTOP
MOSQUISTOP
MOSQUISTOP
MOSQUISTOP



MOSQUISTOP

MOSQUISTOP
MOSQUISTOP MOSQUISTOP



oh Mosquistop
aluminio-mosquiteras





MOSQUITERA ENROLLABLE

ROLLER INSECT SCREEN
MOUSTIQUAIRE ENROULABLE
INSEKTENSCHUTTZ ROLLO



Pág. 4-11

MOSQUITERA ENROLLABLE CAJÓN REDONDO P42 / AUP42 / R35 / R33 / KITS / GUÍAS

ROLLER INSECT SCREEN ROUND BOX / KITS / GUIDES
MOUSTIQUAIRE ENROULABLE CAISSON ROND / KITS /
COULISSES
INSEKTENSCHUTTZ ROLLO / RUNDE KASSETTE / KITS / FÜHRER
GUÍA DOBLE
DOUBLE GUIDE
COULISSE DOUBLE
DOPPELTE FÜHRUNGSSCHIENE

MOSQUITERA PUERTA LATERAL Y PUERTA DOBLE

LATERAL & DOUBLE LATERAL INSECT
SCREEN DOOR
PORTE LATÉRALE ET DOUBLE LATÉRALE
INSEKTENSCHUTTZ ROLLO EINZELTÜR /
DOPPELTÜR-SYSTEM



Pág. 11-13

SISTEMAS PUERTA LATERAL Y PUERTA DOBLE

LATERAL AND DOUBLE LATERAL DOOR SYSTEMS
SYSTÈMES DE PORTE LATÉRALE ET PORTE DOUBLE LATÉRALE
INSEKTENSCHUTZROLLO EINZELTÜR / DOPPELTÜR - SYSTEM

MOSQUITERA FIJA

FIXED INSECT SCREEN
MOUSTIQUAIRE FIXE
SPANNRAHMEN

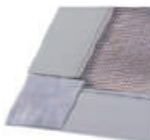

Pág. 16-17

MOSQUITERA FIJA M979

FIXED INSECT SCREEN M979
MOUSTIQUAIRE FIXE M979
SPANNRAHMEN M979

MOSQUITERA CORREDERA

SLIDING INSECT SCREEN
MOUSTIQUAIRE COULISSANTE
INSEKTENSCHUTZ SCHIEBETÜR



Pág. 18-19

MOSQUITERA CORREDERA CURVA 1236 C

SLIDING CURVED INSECT SCREEN 1236 C
MOUSTIQUAIRE COULISSANTE COURBE 1236 C
SCHIEBETÜR FEWÖLBT 1236 C

MOSQUITERA ABATIBLE

HINGED DOOR INSECT SCREEN
MOUSTIQUAIRE PORTE BATTANTE
INSEKTENSCHUTZ SCHWENKTÜR



Pág. 20-22

MOSQUITERA ABATIBLE

HINGED DOOR INSECT SCREEN
MOUSTIQUAIRE PORTE BATTANTE
INSEKTENSCHUTZ SCHWENKTÜR

ROLLOS DE TELA MOSQUITERA Y TUBO CON TELA

INSECT SCREEN MESH ROLLS & TUBE WITH MESH
ROULEAUX DE TOILE MOUSTIQUAIRE ET TUBE AVEC
TISSU
ROLLEN INSEK TENSCHUTZGEWEBE / ROHR MIT GEWEBE



Pág. 23

ROLLOS DE TELA MOSQUITERA Y TUBO CON TELA

INSECT SCREEN MESH ROLLS & TUBE WITH MESH
ROULEAUX DE TOILE MOUSTIQUAIRE ET TUBE AVEC TISSU
ROLLEN INSEK TENSCHUTZGEWEBE / ROHR MIT GEWEBE

MOSQUITERA A MEDIDA

INSECT SCREEN ON MEASUREMENT
MOUSTIQUAIRE SUR MESURE
INSEKTENSCHUTZ NACH MAB



Pág. 24-28

TODOS LOS SISTEMAS DE MOSQUITERA

ALL KIND OF INSECT SCREEN SYSTEMS
TOUS LES SYSTÈMES DE MOUSTIQUAIRES
ALLE MOSKITONETZSYSTEME

ACABADOS

FINISHES
FINITIONS
ANFER TIGUNGEN



Pág. 30-31

ACABADOS

FINISHES
FINITIONS
ANFER TIGUNGEN

GARANTÍA Y CONDICIONES DE VENTA

GUARANTEE AND SALES CONDITIONS
GARANTIE ET CONDITIONS DE VENTE
GARANTIE UND VERKAUFSBEDINGUNGEN



Pág. 32

GARANTÍA Y CONDICIONES DE VENTA

GUARANTEE AND SALES CONDITIONS
GARANTIE ET CONDITIONS DE VENTE
GARANTIE UND VERKAUFSBEDINGUNGEN



P42 Y AUP42

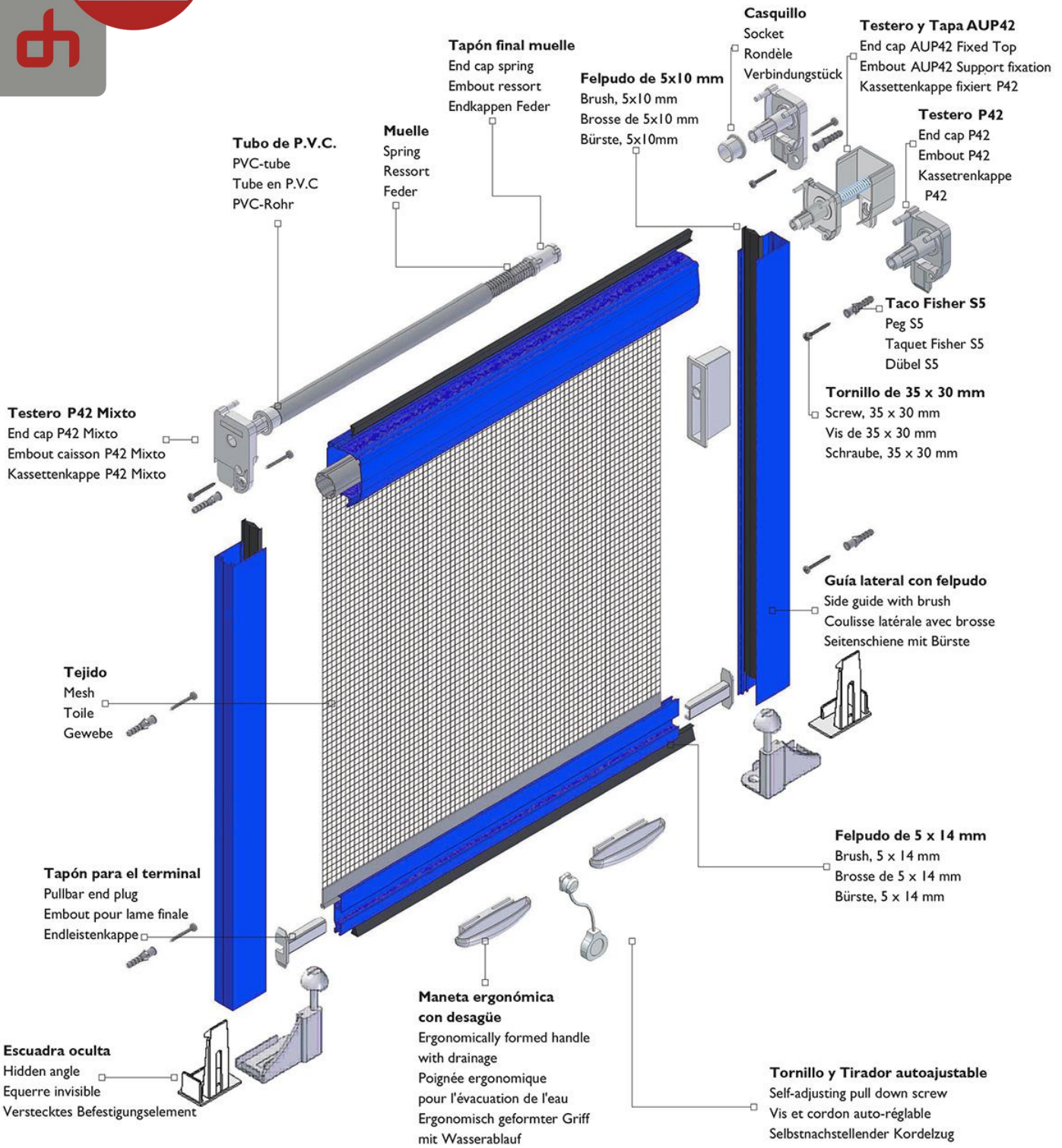

4

Escuadra oculta sujeción terminal

Hidden angle for end profile fixation
Esquerre invisible pour fixation de la lame finale
Unsichtbarer Winkel zur Endleistenbefestigung

Asa tirador autoajustable

Self-adjustable handle and pull down cord
Poignée et cordon auto-réglable
Und Kordelzug

Mosquitera Enrollable Cajón AUP42

Roller Insect Screen box AUP42
Moustiquaire enrollable caisson AUP42
Insektenschutz Rollo Kasette AUP42





TARIFA DE PRECIOS

CAJÓN P42 / TELA Y TERMINAL



PRICE LIST
LISTE DE PRIX
PREISLISTE

P42 BOX , MESH AND END SLOT
CAISSON P42, TOILE ET LAME FINALE
KASSETTE P42, GEWEBE UND ENDSCHIENE

CAJÓN P42 – P42 BOX – CAISSON P42 – KASSETTE P42



P42

	ALTO – HEIGHT – HAUTEUR – HÖHE 1,80 m.	PVP €/ml	ALTO – HEIGHT – HAUTEUR – HÖHE 2,40 m.	PVP €/ml
Brut – Raw – Brut - Roh	00MP42180000	22,72	00MP42240000	23,70
Blanco – White – Blanc - Weiß	00MP42189010	24,35	00MP42249010	26,20
Col. Básico / Plata – Colours / Silver – Couleurs / Argent – Farben / Silber	00MP4218****	27,39	00MP4224****	29,02
Col. Especial / Bronce - Inox – Col. Special / Stainless Steel – Bronze – Col. Speciaux / Inox – Bronze – Sonderfarben / Rostfreier Stahl - Bronze	00MP4218****	30,00	00MP4224****	32,07
Madera – Wood – Ton Bois - Holz	00MP4218****	37,00	00MP4224****	38,55
Foliado – Foliated – Foliè - Foliert	00MP4218****	46,75	00MP4224****	48,57
Embalaje – Packing – Conditionnement - Verpackungseinheiten	M/ barra	4	M/ barra	24

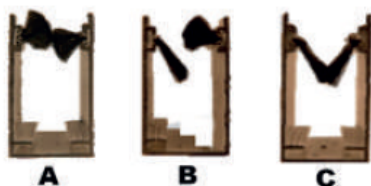

A

B

C

	Gua normal Normal guide Coulisse normal Normale anleitung		Gua mixta antiviento Mixed guide windshield Coilisse antivent mixe Kombiniertes Windschutzsystem		Gua doble antiviento Double guide windproof Coulisse antivent double Doppeltes Windschutzsystem	
	A. Ref.	PVP €/ml	B. Ref.	PVP €/ml	C. Ref.	PVP €/ml
Brut – Raw – Brut - Roh	0000GLAT0000	4,30	AVMXGLAT0000	4,50	AVDBGLAT0000	4,70
Blanco – White – Blanc - Weiß	0000GLAT9010	5,85	AVMXGLAT9010	6,10	AVDBGLAT9010	6,25
Col. Básico / Plata – Colours / Silver – Couleurs / Argent – Farben / Silber	0000GLAT****	6,90	AVMXGLAT****	7,10	AVDBGLAT****	7,30
Col. Especial / Bronce - Inox – Col. Special / Stainless Steel – Bronze – Col. Speciaux / Inox – Bronze – Sonderfarben / Rostfreier Stahl - Bronze	0000GLAT****	8,00	AVMXGLAT****	8,20	AVDBGLAT****	8,40
Madera – Wood – Ton Bois - Holz	0000GLAT****	10,30	AVMXGLAT****	10,50	AVDBGLAT****	10,70
Foliado – Foliated – Foliè - Foliert	0000GLAT****	14,98	AVMXGLAT****	16,50	AVDBGLAT****	18,00
Embalaje – Packing – Conditionnement - Verpackungseinheiten	M / barra	6	M / Box	108	M / Caja	108

KIT / TESTERO P42

END CAP P42 – EMBOUT P42 – KASSETTENKAPPE P42

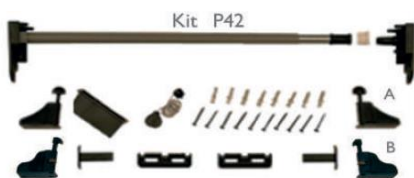

Kit P42

Muelle Mixto Escuadra / tornillo A – Spring Square with screw A – Ressort Esquerre Vis A – Feder Winkel mit Schraube A

Muelle Mixto Tuerca / dorada B – Spring Square with gilted nut B – Ressort Esquerre ecrou dore B – Feder Winkel mit vergoldeter Schraubenmutter B

	Blanco White – Blanc - Weiß	PVP €/Und.	Negro Black – Noir - Schwarz	PVP €/Und.
03KMP42MA0001		5,70	03KMP42MA0002	5,40
03KNP42MA0001		6,10	03KNP42MA0002	5,80

KIT / TESTERO AUP42 Autoanclaje

END CAP AUP42 SELF-FIXATION – EMBOUT AUP42 AUTO-FIXATION – KASSETTENKAPPE SELBSTFIXIERT AUP42



Kit AUP42

Muelle Mixto Escuadra / tornillo A – Spring Square with screw A – Ressort Esquerre Vis A – Feder Winkel mit Schraube A

Muelle Mixto Tuerca / dorada B – Spring Square with gilted nut B – Ressort Esquerre ecrou dore B – Feder Winkel mit vergoldeter Schraubenmutter B

Muelle Mixto Escuadra oculta C – Spring with invisible Square C – Ressort Mixe Esquerre invisible C – Feder mit unsichtbarer Winkel

	Blanco White – Blanc - Weiß	PVP €/Und.	Negro Black – Noir - Schwarz	PVP €/Und.
03KMP42MA0001		6,00	03KMP42MA0002	5,70
03KNP42MA0001		6,40	03KNP42MA0002	6,10
3KMP42MAU0001		6,00	3KMP42MAU0002	5,70

Embalaje – Packing – Conditionnement - Verpackungseinheiten	Unidades / Caja – Units / Box	50
---	-------------------------------	----

Sistema slow ITA - Slow System
– Système slow – Slow System

5,75 €

Incremento por muelle inverso – Increase spring reverse –
Increment ressort sens inverse – Rückgestellte Federerhöhung

2,00
€/NETO

5





R35

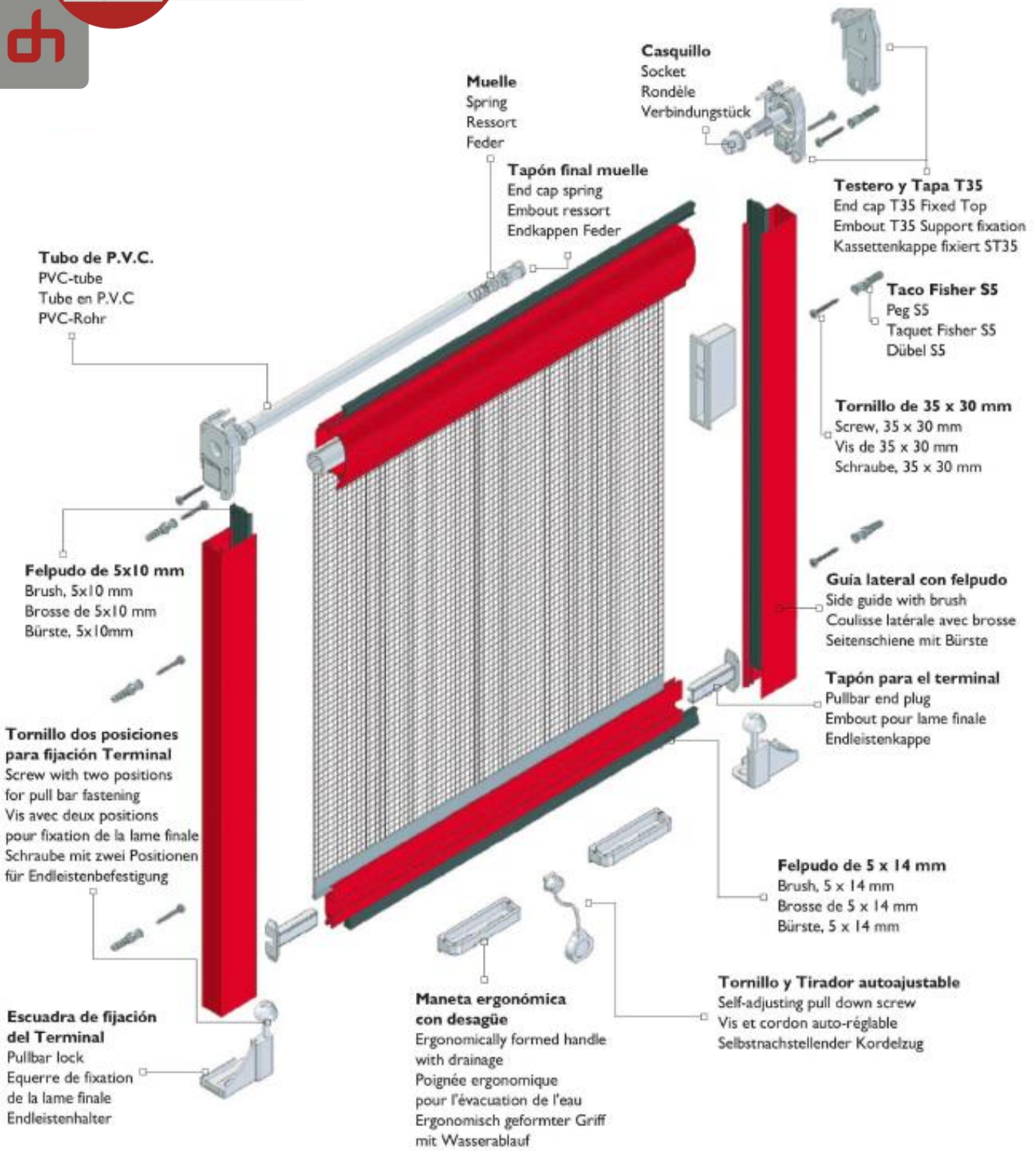

6

Mosquitera Enrollable modelo R35 mm

Roller Insect Screen R35 mm
Moustiquaire enroulable R35 mm
Insektenschutz Rollo R35 mm

Testero y Tapa R35

End cap and support R35
Embout et support R35
Aufnahmelement R35





TARIFA DE PRECIOS

CAJÓN R35 / TELA Y TERMINAL

PRICE LIST
LISTE DE PRIX
PREISLISTE

R35 BOX , MESH AND END SLOT
CAISSON R35, TOILE ET LAME FINALE
KASSETTE R35, GEWEBE UND ENDSCHIENE

CAJÓN R35 – R35 BOX – CAISSON R35 – KASSETTE R35



	ALTO – HEIGHT – HAUTEUR – HÖHE 1,80 m.	PVP €/ml
Brut – Raw – Brut - Roh	00MR35180000	22,00
Blanco – White – Blanc - Weiß	00MR35189010	24,00
Col. Básico / Plata – Colours / Silver – Couleurs / Argent – Farben / Silber	00MR3518****	26,70
Col. Especial / Bronce - Inox – Col. Special / Stainless Steel – Bronze – Col. Speciaux / Inox – Bronze – Sonderfarben / Rostfreier Stahl - Bronze	00MR3518****	29,20
Madera – Wood – Ton Bois - Holz	00MR3518****	36,50
Foliado – Foliated – Foliè - Foliert	00MR3518****	46,19

Embalaje – Packing – Conditionnement - Verpackungseinheiten	M / barra	6	M / Box	24
--	------------------	----------	----------------	-----------

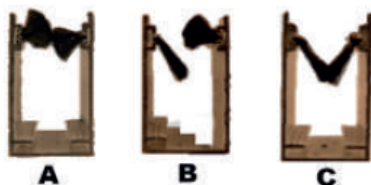

	Guía normal Normal guide Coulisse normal Normale anleitung		Guía mixta antiviento Mixed guide windshield Coilisse antivent mixte Kombiniertes Windschutzsystem		Guía doble antiviento Double guide windproof Coulisse antivent double Doppeltes Windschutzsystem	
	A. Ref.	PVP €/ml	B. Ref.	PVP €/ml	C. Ref.	PVP €/ml
Brut – Raw – Brut - Roh	0000GLAT0000	4,30	AVMXGLAT0000	4,50	AVDBGLAT0000	4,70
Blanco – White – Blanc - Weiß	0000GLAT9010	5,85	AVMXGLAT9010	6,10	AVDBGLAT9010	6,25
Col. Básico / Plata – Colours / Silver – Couleurs / Argent – Farben / Silber	0000GLAT****	6,90	AVMXGLAT****	7,10	AVDBGLAT****	7,30
Col. Especial / Bronce - Inox – Col. Special / Stainless Steel – Bronze – Col. Speciaux / Inox – Bronze – Sonderfarben / Rostfreier Stahl - Bronze	0000GLAT****	8,00	AVMXGLAT****	8,20	AVDBGLAT****	8,40
Madera – Wood – Ton Bois - Holz	0000GLAT****	10,30	AVMXGLAT****	10,50	AVDBGLAT****	10,70
Foliado – Foliated – Foliè - Foliert	0000GLAT****	14,98	AVMXGLAT****	16,50	AVDBGLAT****	18,00
Embalaje – Packing – Conditionnement - Verpackungseinheiten	M / barra	6	M / Box	108	M / Caja	108

KIT / TESTERO Y TAPA R35

END CAP R35 FIXED TOP – EMBOUT R35 SUPPORT FIXATION – KASSETTENKAPPE FIXIERT R35



Muelle Mixto Escuadra / tornillo A – Spring Square with screw A – Ressort Esquerre Vis A – Feder Winkel mit Schraube A

Muelle Mixto Tuerca / dorada B – Spring Square with gilded nut B – Ressort Esquerre ecrou dore B – Feder Winkel mit vergoldeter Schraubenmutter B

Blanco White – Blanc - Weiß	PVP €/Und.	Negro Black – Noir - Schwarz	PVP €/Und.
000KMR35S001	5,40	000KMR35S002	5,10
000KMR35TD01	5,80	000KMR35TD02	5,50

Embalaje – Packing – Conditionnement - Verpackungseinheiten

50 unidades/caja – Units/box



Sistema slow ITA
Slow System – Système slow – Slow System

5,75 €

Incremento por muelle inverso

Increase spring reverse – Increment ressort sens inverse – Rückgestellte Federerhöhung

2,00
€/NETO



R33



Muelle
Spring
Ressort
Feder

Tapón final muelle
End cap spring
Embout ressort
Endkappen Feder

Casquillo
Socket
Rondèle
Verbindungsstück

Felpudo de 5x10 mm
Brush, 5x10 mm
Brosse de 5x10 mm
Bürste, 5x10mm

Tubo de P.V.C.
PVC-tube
Tube en P.V.C
PVC-Rohr

Testero R33 Mixto
End Cap R33 mixed
Embout R33 mixte
Kassettenkappe R33 gemischt

Taco S5
Peg S5
Taquet S5
Dübel S5

Tornillo de 35 x 30 mm
Screw, 35 x 30 mm
Vis de 35 x 30 mm
Schraube, 35 x 30 mm

Guía lateral con felpudo
Side guide with brush
Coulisse latérale avec brosse
Seitenschiene mit Bürste

Tornillo dos posiciones para fijación Terminal
Screw with two positions for pull bar fastening
Vis avec deux positions pour fixation de la lame finale
Schraube mit zwei Positionen für Endleistenbefestigung

Escuadra de fijación del Terminal
Pullbar lock
Equerre de fixation de la lame finale
Endleistenhalter

Maneta ergonómica con desagüe
Ergonomically formed handle with drainage
Poignée ergonomique pour l'évacuation de l'eau
Ergonomisch geformter Griff mit Wasserablauf

Tornillo y Tirador autoajustable
Self-adjusting pull down screw
Vis et cordon auto-réglable
Selbstnachstellender Kordelzug

Felpudo de 5 x 14 mm
Brush, 5 x 14 mm
Brosse de 5 x 14 mm
Bürste, 5 x 14 mm

Tapón para el terminal
Pullbar end plug
Embout pour lame finale
Endleistenkappe

8

Mosquitera Enrollable modelo R33 mm

Roller Insect Screen R33 mm
Moustiquaire enroulable R33 mm
Insektenschutz Rollo R33 mm

Cajones Mini R33

Box Mini R33
Caisson Mini R33
Kassete Mini R33

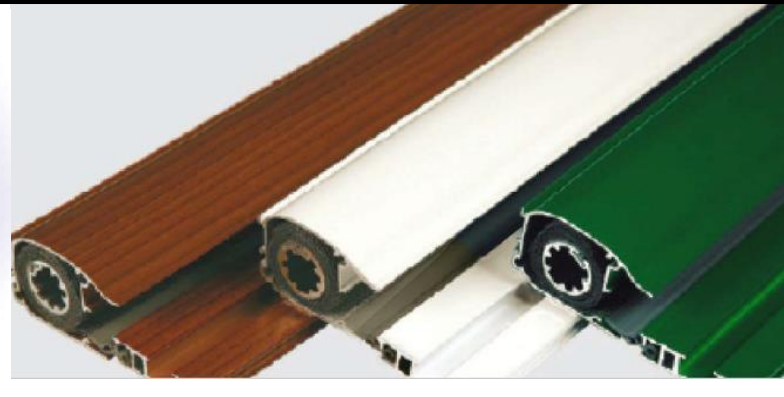
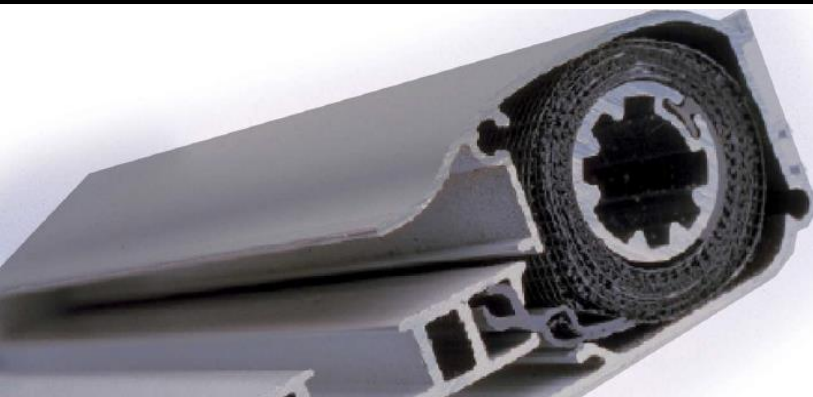



TARIFA DE PRECIOS

CAJÓN R33 / TELA Y TERMINAL

PRICE LIST
LISTE DE PRIX
PREISLISTE

R33 BOX , MESH AND END SLOT
CAISSON R33, TOILE ET LAME FINALE
KASSETTE R33, GEWEBE UND ENDSCHIENE

CAJÓN R33 – R33 BOX – CAISSON R33 – KASSETTE R33

ALTO – HEIGHT –
HAUTEUR – HÖHE
1,40 m.

PVP
€/ml



Brut – Raw – Brut - Roh	000R33140000	18,50
Blanco – White – Blanc - Weiß	000R33149010	20,80
Col. Básico / Plata – Colours / Silver – Couleurs / Argent – Farben / Silber	000R3314****	24,60
Col. Especial / Bronce - Inox – Col. Special / Stainless Steel – Bronze – Col. Speciaux / Inox – Bronze – Sonderfarben / Rostfreier Stahl - Bronze	000R3314****	28,00
Madera – Wood – Ton Bois - Holz	000R3314****	34,00
Foliado – Foliated – Foliè - Foliert	000R3314****	40,00
Embalaje – Packing – Conditionnement - Verpackungseinheiten	M / barra	6
	M / Box	24

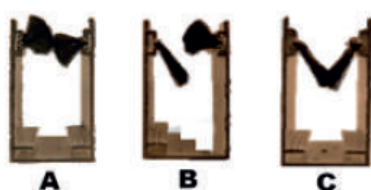

	Guía normal Normal guide Coulisse normal Normale anleitung		Guía mixta antiviento Mixed guide windshield Coilisse antivent mixe Kombiniertes Windschutzsystem		Guía doble antiviento Double guide windproof Coulisse antivent double Doppeltes Windschutzsystem	
	A. Ref.	PVP €/ml	B. Ref.	PVP €/ml	C. Ref.	PVP €/ml
Brut – Raw – Brut - Roh	0000GLAT0000	4,30	AVMXGLAT0000	4,50	AVDBGLAT0000	4,70
Blanco – White – Blanc - Weiß	0000GLAT9010	5,85	AVMXGLAT9010	6,10	AVDBGLAT9010	6,25
Col. Básico / Plata – Colours / Silver – Couleurs / Argent – Farben / Silber	0000GLAT****	6,90	AVMXGLAT****	7,10	AVDBGLAT****	7,30
Col. Especial / Bronce - Inox – Col. Special / Stainless Steel – Bronze – Col. Speciaux / Inox – Bronze – Sonderfarben / Rostfreier Stahl - Bronze	0000GLAT****	8,00	AVMXGLAT****	8,20	AVDBGLAT****	8,40
Madera – Wood – Ton Bois - Holz	0000GLAT****	10,30	AVMXGLAT****	10,50	AVDBGLAT****	10,70
Foliado – Foliated – Foliè - Foliert	0000GLAT****	14,98	AVMXGLAT****	16,50	AVDBGLAT****	18,00
Embalaje – Packing – Conditionnement - Verpackungseinheiten	M / barra	6	M / Box	108	M / Caja	108

KIT / TESTERO R33

END CAP R33 FIXED TOP – EMBOUT R33 SUPPORT FIXATION – KASSETTENKAPPE FIXIERT R33



Muelle Mixto Escuadra / tornillo A – Spring Square with screw A – Ressort Esquerre Vis A – Feder Winkel mit Schraube A

Muelle Mixto Tuerca / dorada B – Spring Square with gilded nut B – Ressort Esquerre ecrou dore B – Feder Winkel mit vergoldeter Schraubenmutter B

Embalaje – Packing – Conditionnement - Verpackungseinheiten

	Blanco White – Blanc - Weiß	PVP €/Und.	Negro Black – Noir - Schwarz	PVP €/Und.
	000KMR33S001	5,40	000KMR33S002	5,10
	000KMR33TD01	5,80	000KMR33TD02	5,50
Embalaje – Packing – Conditionnement - Verpackungseinheiten				50 unidades/caja – Units/box

Sistema slow ITA
Slow System – Système slow – Slow System

5,75€

Incremento por muelle inverso
Increase spring reverse – Increment ressort sens inverse – Rückgestellte Federerhöhung

2,00
€/NETO



GDO

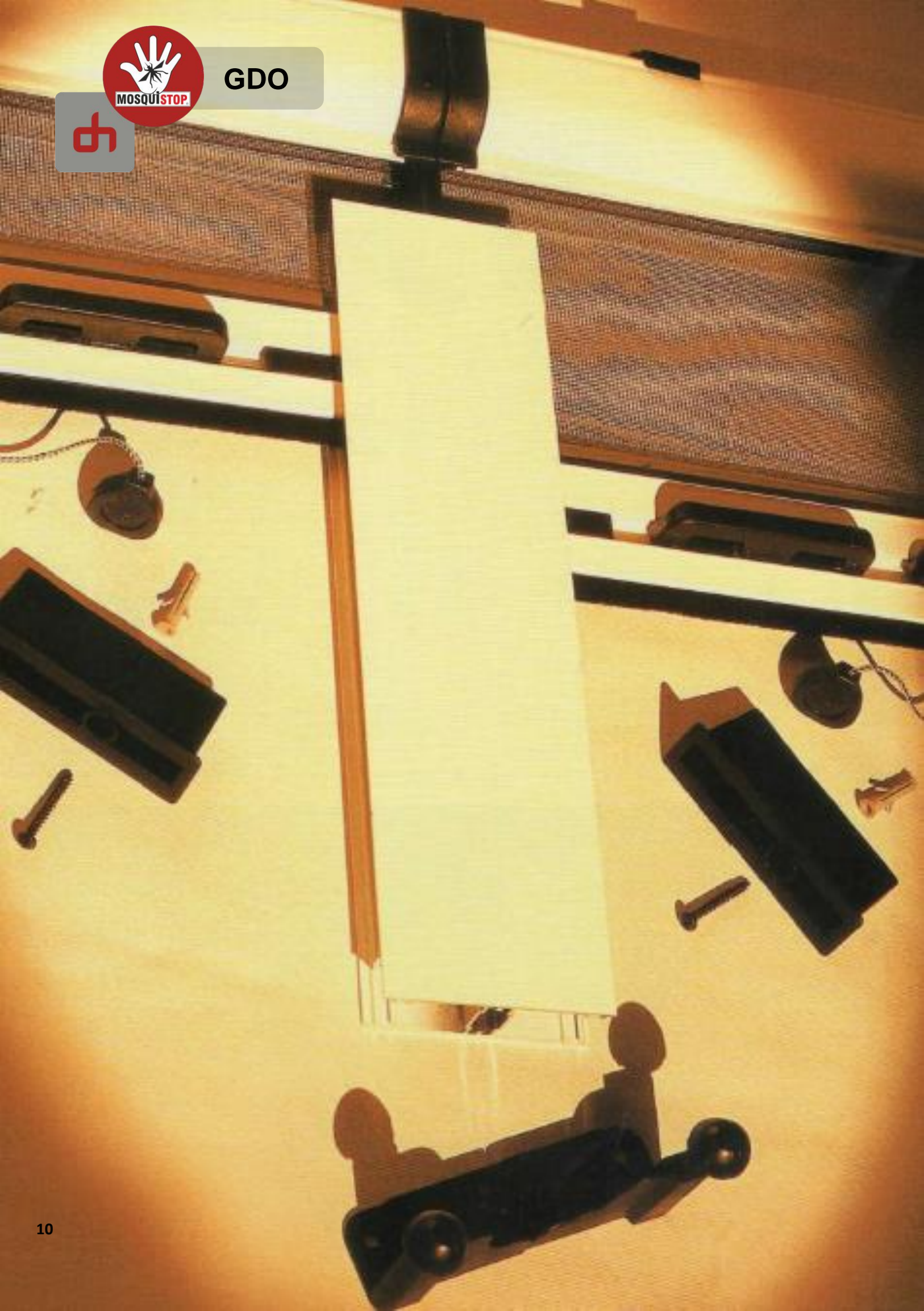



PRICE LIST
LISTE DE PRIX
PREISLISTE

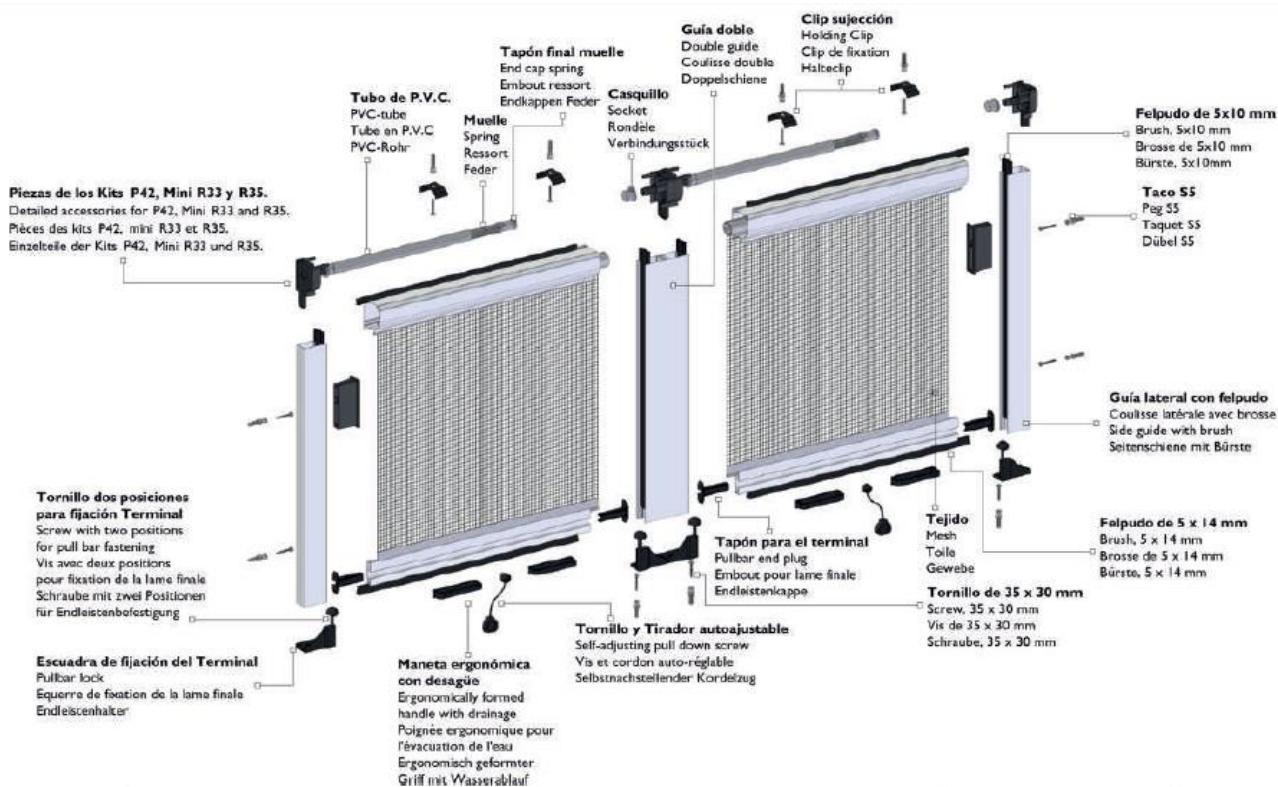

GUÍA DOBLE SISTEMA CABEZAL PARTIDO DOUBLE GUIDE DIVIDED BOX SYSTEM – COULISSE DOUBLE SYSTÈME CAISSON DIVISÉ – DOPPELTE FÜHRUNGSSCHIENE GETEILTE KASSETTE	Ref.	PVP €/ml
Brut – Raw – Brut - Roh	0000GDOB0000	9,40
Blanco – White – Blanc - Weiß	0000GDOB9010	11,70
Col. Básico / Plata – Colours / Silver – Couleurs / Argent – Farben / Silber	0000GDOB****	13,80
Col. Especial / Bronce - Inox – Col. Special / Stainless Steel – Bronze – Col. Speciaux / Inox – Bronze – Sonderfarben / Rostfreier Stahl - Bronze	0000GDOB****	16,00
Madera – Wood – Ton Bois - Holz	0000GDOB****	20,60
Foliado – Foliated – Folié - Foliert	0000GDOB****	30,00



Guía doble con felpudo
Double guide with brush
Coulisse double avec joint brosse
Doppelschiene mit Bürste

Brut – Raw – Brut - Roh	AVMXGDOB0000	9,80
Blanco – White – Blanc - Weiß	AVMXGDOB9010	12,20
Col. Básico / Plata – Colours / Silver – Couleurs / Argent – Farben / Silber	AVMXGDOB****	14,20
Col. Especial / Bronce - Inox – Col. Special / Stainless Steel – Bronze – Col. Speciaux / Inox – Bronze – Sonderfarben / Rostfreier Stahl - Bronze	AVMXGDOB****	16,40
Madera – Wood – Ton Bois - Holz	AVMXGDOB****	21,00
Foliado – Foliated – Folié - Foliert	AVMXGDOB****	33,00

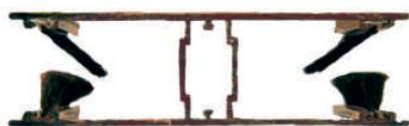

Guía Doble sistema Mixto Antiviento
Combined windproof system double guide
Coulisse double système mixte anti-vent
Doppelschiene mit Windbürste Kombiniertes

Brut – Raw – Brut - Roh	AVDBGDOB0000	9,30
Blanco – White – Blanc - Weiß	AVDBGDOB9010	10,45
Col. Básico / Plata – Colours / Silver – Couleurs / Argent – Farben / Silber	AVDBGDOB****	11,50
Col. Especial / Bronce - Inox – Col. Special / Stainless Steel – Bronze – Col. Speciaux / Inox – Bronze – Sonderfarben / Rostfreier Stahl - Bronze	AVDBGDOB****	12,60
Madera – Wood – Ton Bois - Holz	AVDBGDOB****	14,90
Foliado – Foliated – Folié - Foliert	AVDBGDOB****	23,40



Guía doble sistema Antiviento Doble
Windproof double system double guide
Coulisse double système double anti-vent
Doppelschiene mit doppelter Windbürste

Embalaje – Packing – Conditionnement - Verpackungseinheiten	M / barra	6	M / Box	30
---	-----------	---	---------	----



PL



PUERTA LATERAL
LATERAL DOOR SYSTEM
SYSTEME PORTE LATÉRALE
INSEKTENSCHUTZROLLO EINZELTÜR

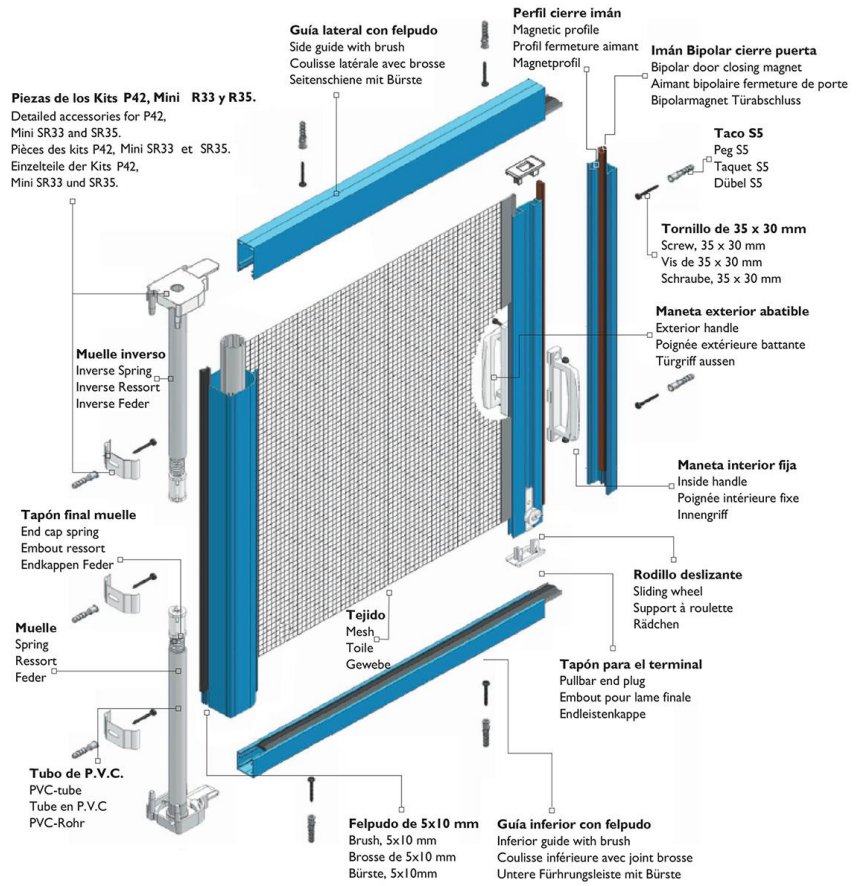

PDL



PUERTA DOBLE LATERAL
DOUBLE LATERAL DOOR SYSTEM
PORTE DOUBLE LATÉRALE
DOPPELTÜR

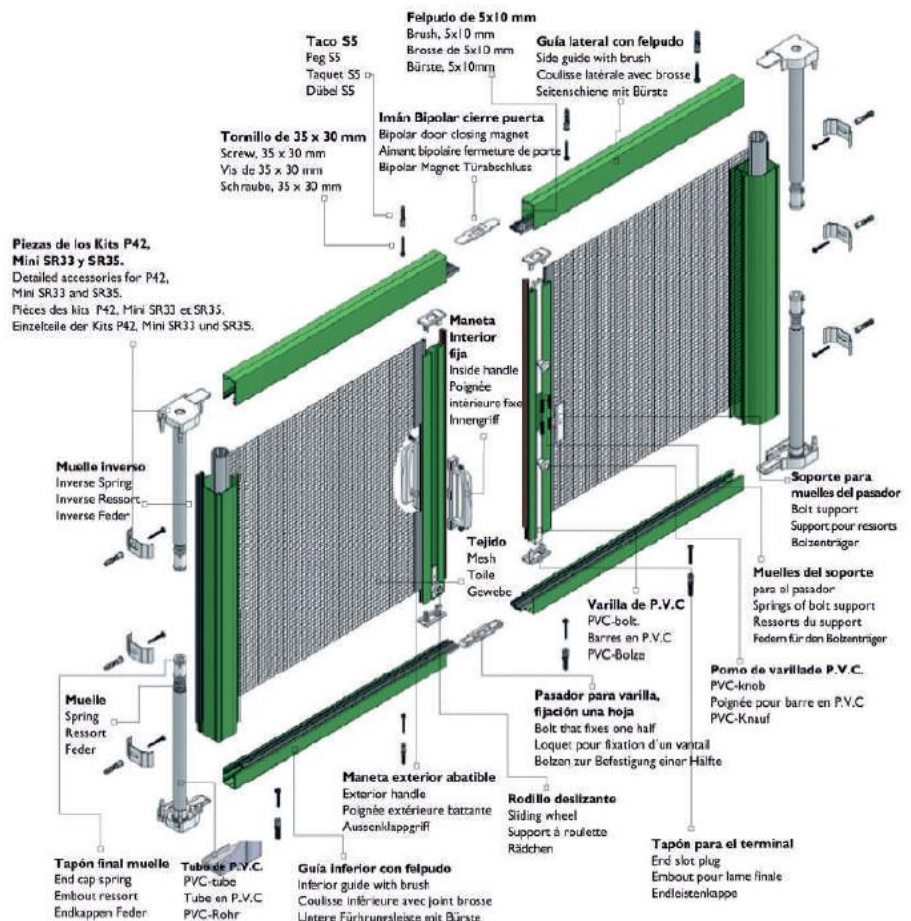



PRICE LIST
LISTE DE PRIX
PREISLISTE

KITS PUERTA LATERAL CON MUELLE INVERSO

LATERAL DOOR KIT WITH INVERSE SPRING – KIT PORTE LATÉRALE AVEC RESSORT INVERSE – KIT SEINTENTÜR MIT INVERSE FEDER

KIT PUERTA LATERAL CON MUELLE INVERO Lateral door kit with inverse spring – Kit porte latérale avec ressort inverse – Kit Seitentür mit Inverse Feder	TESTERO End cap – Embout - Kassettenkappe	ALTURA HASTA 2,10 cm Height up to 2,10 cm – Hauteur jusqu'à 2,10 cm – Höhe bis 2,10 cm	Ref. Blanco White – Blanc - Weiß	PVP €/Und.	Ref. Negro Black – Noir - Schwarz	PVP €/Und.
			PL 	P42	Kit P42 Puerta Lateral P42 Lateral Door Kit – Kit P42 Porte Latérale – Kit P42 Seitenrolltür	OKMP42PL0001
Embalaje – Packing – Conditionnement - Verpackungseinheiten					50 unidades/caja – Units/box	

SISTEMA PUERTA LATERAL – SIDE DOOR SYSTEM – SYSTÈME PORTE LATÉRALE – SEINTENTÜR SYSTEM



Guía Inferior con felpudo
Lower guide with brush
Coulisse inférieure avec joint brosse
Untere Führungsschiene mit Bürste

Brut – Raw – Brut - Roh	0000GINF0000	5,00
Blanco – White – Blanc - Weiß	0000GINF9010	5,60
Col. Básico / Plata – Colours / Silver – Couleurs / Argent – Farben / Silber	0000GINF****	6,20
Col. Especial / Bronce - Inox – Col. Special / Stainless Steel – Bronze – Col. Speciaux / Inox – Bronze – Sonderfarben / Rostfreier Stahl - Bronze	0000GINF****	6,70
Madera – Wood – Ton Bois - Holz	0000GINF****	7,80



Guía cierre con imán
Closing profile with magnet
Coulisse fermeture aimant
Magnetaufnahme

Brut – Raw – Brut - Roh	0000GMAG0000	7,50
Blanco – White – Blanc - Weiß	0000GMAG9010	8,00
Col. Básico / Plata – Colours / Silver – Couleurs / Argent – Farben / Silber	0000GMAG****	8,60
Col. Especial / Bronce - Inox – Col. Special / Stainless Steel – Bronze – Col. Speciaux / Inox – Bronze – Sonderfarben / Rostfreier Stahl - Bronze	0000GMAG****	9,20
Madera – Wood – Ton Bois - Holz	0000GMAG****	10,30

Embalaje – Packing – Conditionnement - Verpackungseinheiten

M / barra

5

M / Box

50

IMÁN TRIPOLAR N-S PUERTA LATERAL

350 m M/L

0000ITRI-0000

4,00€

KITS SISTEMA PUERTA DOBLE LATERAL

DOUBLE LATERAL DOOR SYSTEM – SYSTÈME DE PORTE DOUBLE LATÉRALE – DOPPELSEINTENTÜR

KIT PUERTA DOBLE LATERAL CON MUELLE INVERSO Double Lateral door kit with inverse spring Kit porte latérale double avec ressort inverse Kit doppelseitentür mit Inverse Feder	TESTERO End cap – Embout - Kassettenkappe	ALTURA HASTA 2,10 cm Height up to 2,10 cm – Hauteur jusqu'à 2,10 cm – Höhe bis 2,10 cm	Blanco White – Blanc - Weiß	PVP €/Und	Negro Black – Noir - Schwarz	PVP €/Und
PDL 	P42	Kit P42 Puerta Doble Lateral P42 Double Lateral Door Kit – Kit P42 Porte Latérale double – Kit P42 Doppelseitentür	OKMP42PL0001	32,00	OKMP42PL0002	31,40
Embalaje – Packing – Conditionnement - Verpackungseinheiten					50 unidades/caja – Units/box	





TARIFA DE PRECIOS

PERFILERÍA DE ALUMINIO

PRICE LIST
LISTE DE PRIX
PREISLISTE

ALUMINIUM PROFILES
PROFIL D'ALUMINIUM
ALUMINIUMPROFIL

CAJÓN MOSQUITERA – BOX INSECT SCREEN – CAISSON MOUSTIQUAIRE – KASSETTE INSEKTENSCHUTZ



Perfil 1211 A Cajón P/42

Profiles 1211 A Box insect screen P/42
Profil 1211 A Caisson Moustiquaire P/42
Profile 1211 A Kasette insektenschutz P/42

	Ref.	PVP €/ml
Brut – Raw – Brut - Roh	000A12110000	8,10
Blanco – White – Blanc - Weiß	000A12119010	9,57
Col. Básico / Plata – Colours / Silver – Couleurs / Argent – Farben / Silber	000A1211****	10,87
Col. Especial / Bronce – Inox - Col. Special / Stainless Steel – Bronze – Col. Speciaux / Inox – Bronze – Sonderfarben / Rostfreier Stahl - Bronze	000A1211****	12,24
Madera – Wood – Ton Bois - Holz	000A1211****	15,15
Foliado – Foliated – Foliè - Foliert	000A1211****	21,00



Perfil 1209 A Cajón R/35

Profiles 1211 A Box insect screen R/35
Profil 1211 A Caisson Moustiquaire R/35
Profile 1211 A Kasette insektenschutz R/35

Brut – Raw – Brut - Roh	000A12090000	6,52
Blanco – White – Blanc - Weiß	000A12099010	7,76
Col. Básico / Plata – Colours / Silver – Couleurs / Argent – Farben / Silber	000A1209****	8,86
Col. Especial / Bronce – Inox - Col. Special / Stainless Steel – Bronze – Col. Speciaux / Inox – Bronze – Sonderfarben / Rostfreier Stahl - Bronze	000A1209****	10,02
Madera – Wood – Ton Bois - Holz	000A1209****	12,47
Foliado – Foliated – Foliè - Foliert	000A1209****	18,00



Perfil 1213 A Cajón R/33

Profiles 1211 A Box insect screen R/33
Profil 1211 A Caisson Moustiquaire R/33
Profile 1211 A Kasette insektenschutz R/33

Brut – Raw – Brut - Roh	000A12130000	6,15
Blanco – White – Blanc - Weiß	000A12139010	7,31
Col. Básico / Plata – Colours / Silver – Couleurs / Argent – Farben / Silber	000A1213****	8,34
Col. Especial / Bronce – Inox - Col. Special / Stainless Steel – Bronze – Col. Speciaux / Inox – Bronze – Sonderfarben / Rostfreier Stahl - Bronze	000A1213****	9,42
Madera – Wood – Ton Bois - Holz	000A1213****	11,72
Foliado – Foliated – Foliè - Foliert	000A1213****	17,00



Perfil 1067 Terminal Mosquitera

Profile 1067 Insect screen endstlot
Profil 1067 Terminal Moustiquaire
Profile 1067 Insektenschutz Endlamelle

Brut – Raw – Brut - Roh	000A10670000	4,78
Blanco – White – Blanc - Weiß	000A10679010	5,55
Col. Básico / Plata – Colours / Silver – Couleurs / Argent – Farben / Silber	000A1067****	6,24
Col. Especial / Bronce – Inox - Col. Special / Stainless Steel – Bronze – Col. Speciaux / Inox – Bronze – Sonderfarben / Rostfreier Stahl - Bronze	000A1067****	6,96
Madera – Wood – Ton Bois - Holz	000A1067****	8,49
Foliado – Foliated – Foliè - Foliert	000A1067****	14,29



Perfil 1186

Profile - Profil - Profile



Perfil 1175

Profile - Profil - Profile

Brut – Raw – Brut - Roh	000A11860000	4,35
Brut – Raw – Brut - Roh	000A11750000	4,20



200 mts rollo felpudo 5x10 – Brush – Joint brosse - Bürste	00PP51000002	0,26
150 mts rollo felpudo 5x14 – Brush – Joint brosse - Bürste	00PP51400002	0,40



500 mts rollo felpudo antiviento 5x15 – 45° – Windproof Brush – Joint brosse antivent – Bürste windschutz	00PPA4500002	0,70
--	--------------	------



Perfil E0041 Guía Lateral

Profile E0041 Side guide
Profil E0041 Coulisse latérale
Profile E0041 Führer

Brut – Raw – Brut - Roh	000E00410000	4,29
Blanco – White – Blanc - Weiß	000E00419010	5,45
Col. Básico / Plata – Colours / Silver – Couleurs / Argent – Farben / Silber	000E0041****	6,48
Col. Especial / Bronce – Inox - Col. Special / Stainless Steel – Bronze – Col. Speciaux / Inox – Bronze – Sonderfarben / Rostfreier Stahl - Bronze	000E0041****	7,56
Madera – Wood – Ton Bois - Holz	000E0041****	9,86
Foliado – Foliated – Foliè - Foliert	000E0041****	20,00



Guía inferior 1069

Lower guide
Coulisse inférieure
Untere Führer

Brut – Raw – Brut - Roh	00010690000	3,50
Blanco – White – Blanc - Weiß	00010699010	4,10
Col. Básico / Plata – Colours / Silver – Couleurs / Argent – Farben / Silber	0001069****	4,60
Col. Especial / Bronce – Inox - Col. Special / Stainless Steel – Bronze – Col. Speciaux / Inox – Bronze – Sonderfarben / Rostfreier Stahl - Bronze	0001069****	5,20
Madera – Wood – Ton Bois - Holz	0001069****	6,70



Guía cierre imán 1068

Closing profile
Coulisse fermeture
Anfnahme

Brut – Raw – Brut - Roh	00010680000	4,60
Blanco – White – Blanc - Weiß	00010689010	5,30
Col. Básico / Plata – Colours / Silver – Couleurs / Argent – Farben / Silber	0001068****	5,60
Col. Especial / Bronce – Inox - Col. Special / Stainless Steel – Bronze – Col. Speciaux / Inox – Bronze – Sonderfarben / Rostfreier Stahl - Bronze	0001068****	6,30
Madera – Wood – Ton Bois - Holz	000E0041****	7,60

Embalaje – Packing – Conditionnement - Verpackungseinheiten

M / barra

6

M / Box

60



MOSQUITERA FIJA

FIXED INSECT SCREEN

MOUSTIQUAIRE FIXE

SPANNRAHMEN

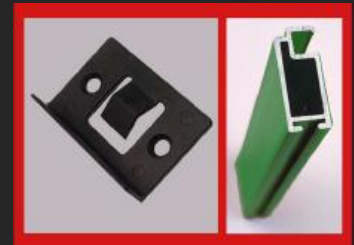
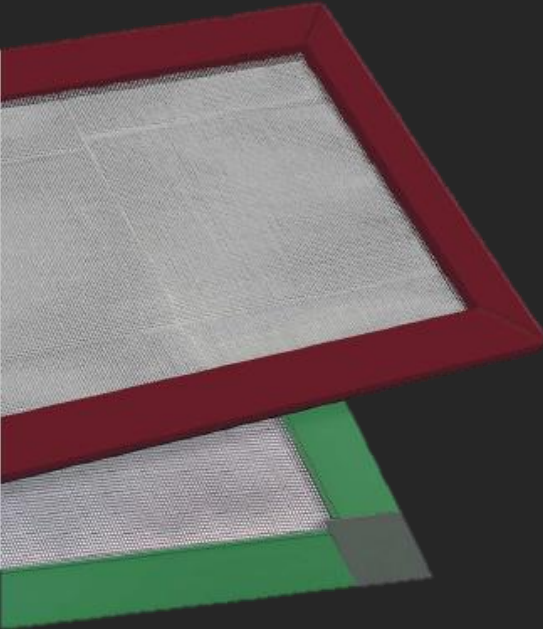

MOSQUITERA CORREDERA

SLIDING INSECT SCREEN

MOUSTIQUAIRE COULISSANTE

INSEKTENSCHUTZ SCHIEBETÜR

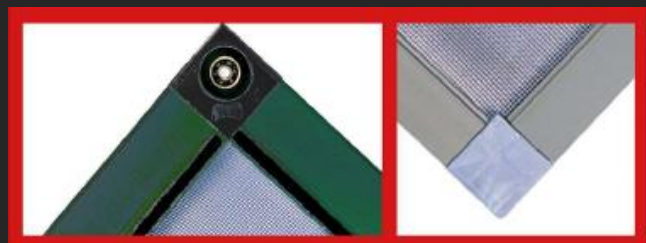



M979 MOSQUITERA FIJA

FIXED INSECT SCREEN
MOUSTIQUAIRE FIXE
SPANNRAHMEN

**Escuadra (negra, blanca, plata y
bronce)**
Angle (black, white, silver, bronze)
Equerre (noir, blanc, argent et bronze)
Winkel (schwarz, weiss, silber, bronze)

Felpudo de 7 x 6 mm
Brush 7 x 6 mm
Joint brosse de 7 x 6 mm
Bürste 7 x 6 mm

Perfiles de mosquitera fija de corte recto
Fixed Insect Screen profile, straight-cut
Profil de moustiquaire fixe de coupe droite
Gerade geschnittenes Spannrahmenprofil

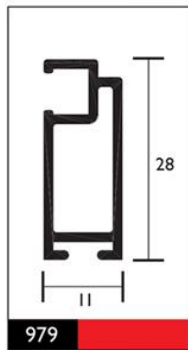

979



Tejido
Mesh
Toile
Gewebe

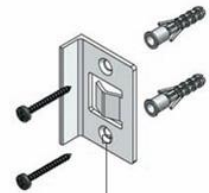

Soporte de Nylon
Nylonclip
Support en nylon
Nylonclip

Goma sujeción tejido de Ø 6 mm
Rubber 6 mm, mesh fixation
Joint en P.V.C de Ø 6 mm pour soutenir la toile
Keder 6 mm, Gewebefestigung

Perfil Ref. M979
Profile ref. M979
Profil réf. M979
Profil Ref M979

Perfil ref. M979

Profile ref. M979
Profil ref. M979
Profile ref. M979

Escuadra mosquitera fija OESFI 000000*

Fixed insect screen angle
Esquerre moustiquaire fixe
Fester Insektenschutz Winkel

Goma 6 mm sujeción tejido

Rubber 6 mm mesh fixation
Joint 6 mm fixation toile
Keder 6 mm gewebefestigung

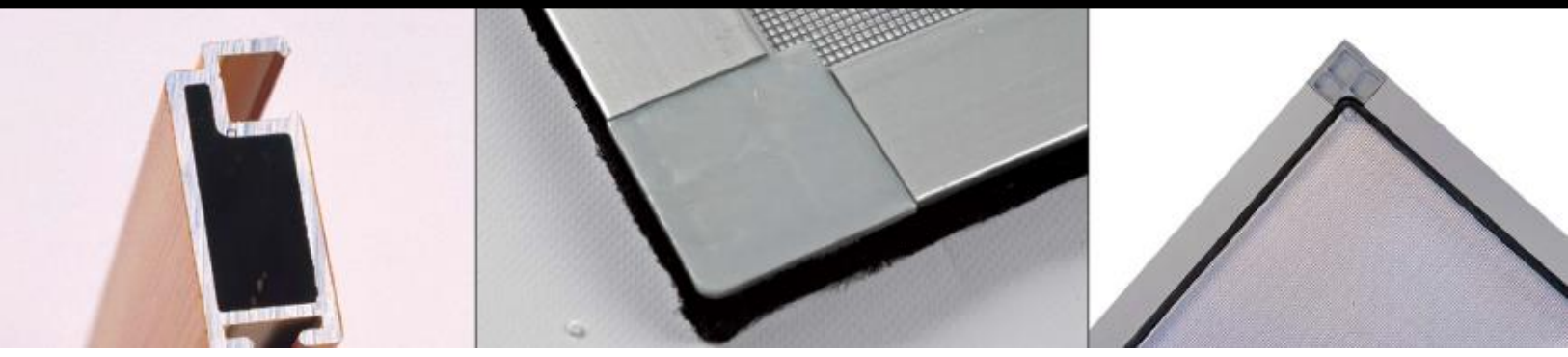



PRICE LIST
LISTE DE PRIX
PREISLISTE

MOSQUITERA FIJA

FIXED INSECT SCREEN – MOUSTIQUAIRE FIXE - SPANNRAHMEN

PERFIL – PROFILE – PROFIL - PROFIL



Perfil Fija M979
M979 Fixed Profile
Profil fixe M979
Spannrahmenprofil M979

	Ref.	PVP €/ml
Brut – Raw – Brut - Roh	0000M9790000	4,16
Blanco – White – Blanc - Weiß	0000M9799010	4,78
Col. Básico / Plata – Colours / Silver – Couleurs / Argent – Farben / Silber	0000M979****	5,33
Col. Especial / Bronce – Inox - Col. Special / Stainless Steel – Bronze – Col. Speciaux / Inox – Bronze – Sonderfarben / Rostfreier Stahl - Bronze	0000M979****	5,90
Madera – Wood – Ton Bois - Holz	0000M979****	7,13
Foliado – Foliated – Foliè - Foliert	0000M979****	14,00

Embalaje – Packing – Conditionnement - Verpackungseinheiten	M / barra	6	M / Box	60
--	------------------	----------	----------------	-----------

DESPIECE ACCESORIOS – DETAILED ACCESSORIES . DETAIL DES ACCESSOIRES . ZUBEHÖR



	Ref.	PVP €/Und.
Juego escuadras mosquitera fija PVC (4 uds.) PVC angle set (4 units) – Jeu d'équerres PVC (4 unités) – Set Eckverbinder PVC (4 stück)	000ESFIJ000*	3,00
Soporte negro de nylon (2 uds.) Black nylon support (2 units) – Support noir en nylon (2 unités) – Schwarzer nylonhalterung (2 stück)	00SPNYFI0002	0,42
Goma sujeción tejido de 6 mts. 6 mts Rubber for mesh fixation – Joint PVC 6 mts fixation toile – Keder 6 mts zur Gewebefestigung	10GM60FI0002	0,40
Tornillos de 3,5 x 32 mm (4 uds.) 3,5 x 32 mm Screw (4 units) – Vis 3,5 x 32 mm (4 unités) – Schrauben 3,5 x 32 mm (4 stück)	00TN35320002	0,10
Tacos Fisher S5 (4 unidades) Fisher Peg S5 (4 units) – Cheville Fisher S5 (4 unités) – Dübel Fischer S5 (4 stück)	000TFD510000	0,05
Felpudo negro de 7 x 6 mts Black brush 7x6 mts – Joint brosse 7x6 mts noir – Schwarze Bürste 7x6 mts	00PP70600002	0,30

Embalaje – Packing – Conditionnement - Verpackungseinheiten	Unidades / Caja – Units / Box	60
--	--------------------------------------	-----------

Manual de instalación Mosquitera Fija

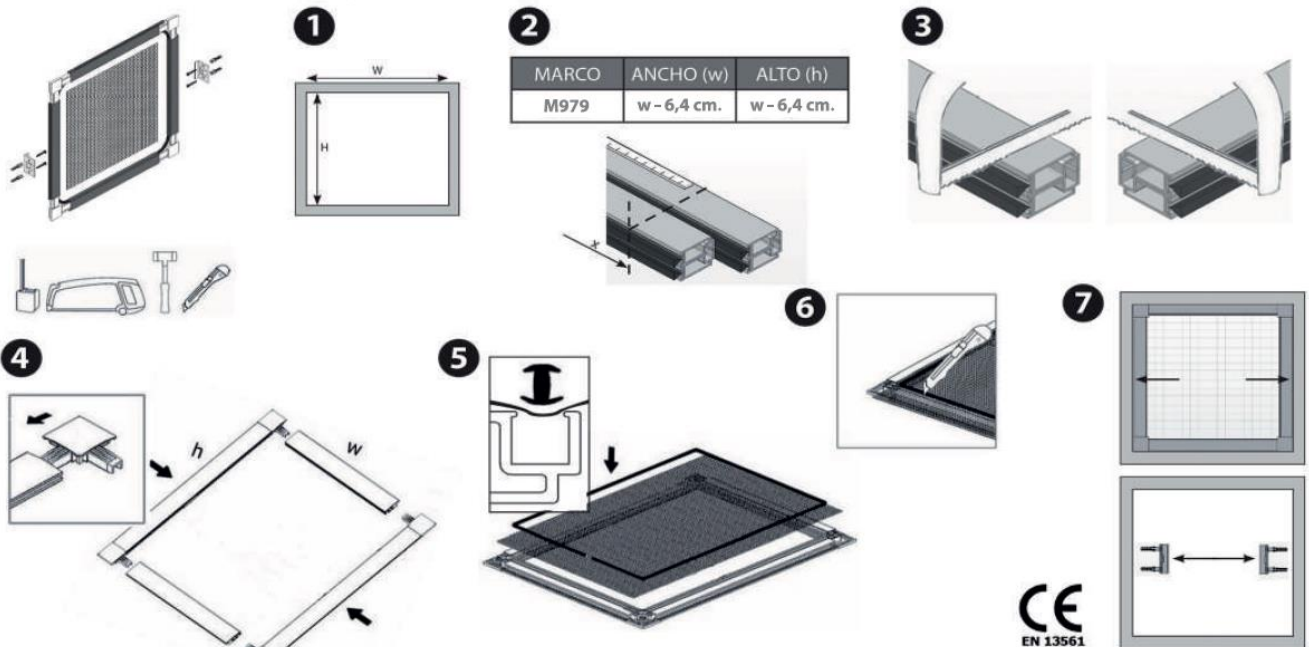

- 1.- Tome la medida de alto y ancho del hueco.
- 2.- Aplique los descuentos según tabla.
- 3.- Corte por separado según el alto o el ancho.
- 4.- Inserte las escuadras en los perfiles tal y como se indica en la figura. Termine el ensamblaje con ayuda del martillo de plástico.

- 5.- Ponga la tela sobre la mosquitera y coloque el burlete como se indica en la figura con ayuda del martillo de plástico.
- 6.- Corte con la ayuda de un cúter la tela sobrante. Apoye el cúter sobre el perfil como indica la imagen.
- 7.- Compruebe que la mosquitera se adecúa al hueco y marque la mejor situación de los clips de fijación en este. A continuación, extraiga la mosquitera e instale los clips de fijación.



1236C MOSQUITERA CORREDERA

SLIDING INSECT SCREEN
MOUSTIQUAIRE COULISSANTE
INSEKTENSCHUTZ SCHIEBETÜR



Escuadra corredera superior (negra, blanca, plata y bronce)
Upper angle, sliding insect screen (black, white, silver, bronze)
Équerre coulissante supérieure (noir, blanc, argent et bronze)
Oberer Winkel, Schiebe insektenschutz (schwarz, weiss, silber, bronze)

Perfiles Ref. 1236-C
Profiles ref. 1236-C
Profils réf. 1236-C
Profile Ref. 1236-C

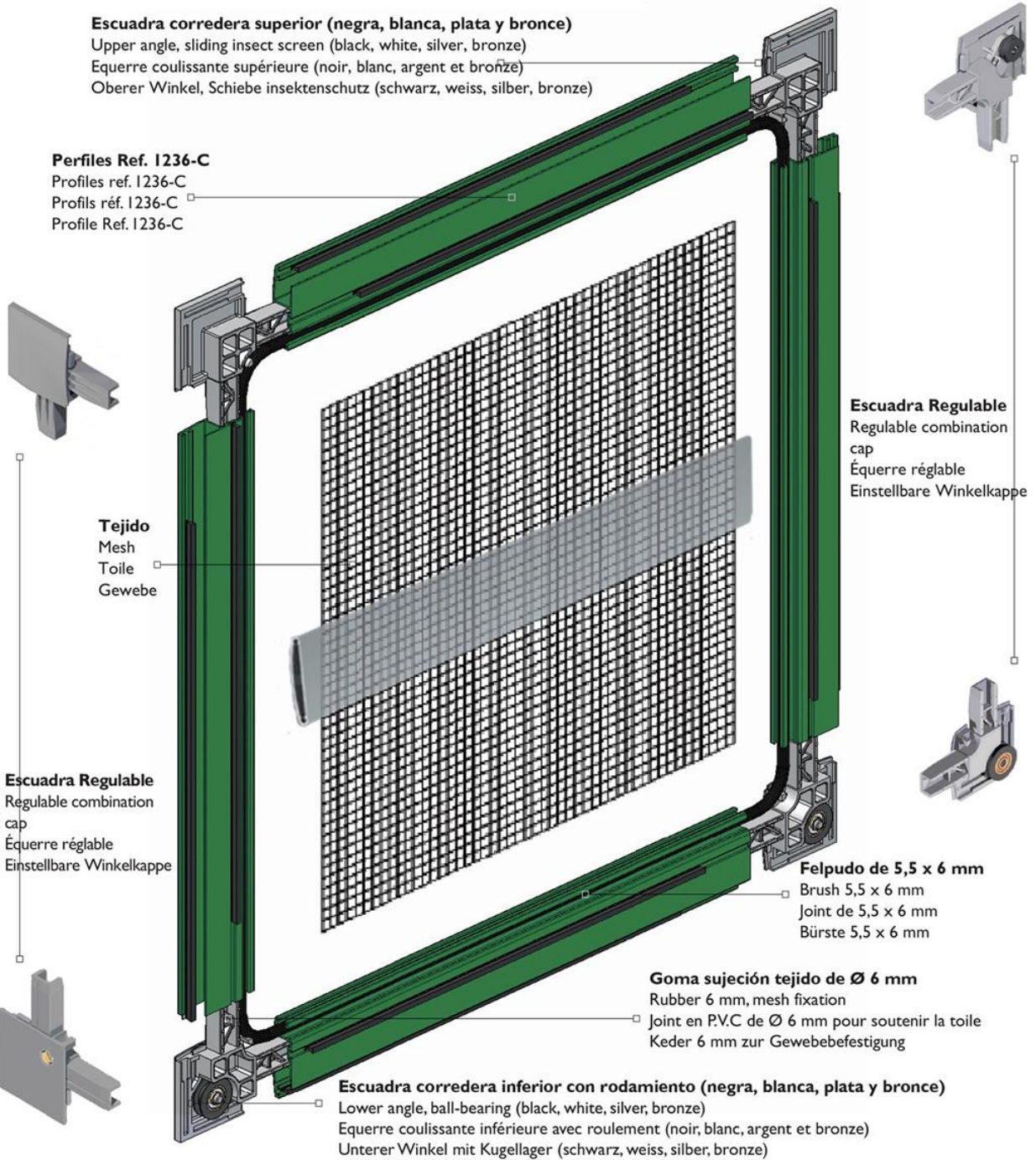

18

Rodamiento de la escuadra inferior

Ballbearing of lower angel
Roulement de l'équaire
Kugellager unterer winkel

Perfil ref. 1236C

Profile ref. 1236C
Profils ref. 1236C
Profile ref. 1236C

Detalle perfil travesero y soporte montados





Detail profile intermediate and support mounted
Detail profil intermédiaire et support installé
Detail-Zwischenprofil und Halterung





PRICE LIST
LISTE DE PRIX
PREISLISTE

PERFIL – PROFILE – PROFIL - PROFIL

		Ref.	PVP €/ml
 <p>Perfil Corredera 1236C 1236C Sliding Profile Profil coulissante 1236C Profil 1236C Schiebetür</p>	Brut – Raw – Brut - Roh	000C12360000	5,55
	Blanco – White – Blanc - Weiß	000C12369010	6,30
	Col. Básico / Plata – Colours / Silver – Couleurs / Argent – Farben / Silber	000C1236****	7,25
	Col. Especial / Bronce – Inox - Col. Special / Stainless Steel – Bronze – Col. Speciaux / Inox – Bronze – Sonderfarben / Rostfreier Stahl - Bronze	000C1236****	8,25
	Madera – Wood – Ton Bois - Holz	000C1236****	10,15
 <p>Perfil Corredera 1236C con dos felpudos 1236C Sliding Profile with two brushes Profil coulissante 1236C Avec deux joint brosse Profil 1236C Schiebetür Mit zwei Bürsten</p>	Blanco – White – Blanc - Weiß	02C12369010	6,45
	Col. Básico / Plata – Colours / Silver – Couleurs / Argent – Farben / Silber	02C1236****	7,35
	Col. Especial / Bronce – Inox - Col. Special / Stainless Steel – Bronze – Col. Speciaux / Inox – Bronze – Sonderfarben / Rostfreier Stahl - Bronze	02C1236****	10,00
	Madera – Wood – Ton Bois - Holz	02C1236****	11,80
 <p>Travesero intermedio recto Intermediate profile Intermédiaire profile Zwischenprofil</p>	Brut – Raw – Brut - Roh	000108020000	4,40
	Blanco – White – Blanc - Weiß	000108029010	5,25
	Col. Básico / Plata – Colours / Silver – Couleurs / Argent – Farben / Silber	00010802****	9,20
	Col. Especial / Bronce – Inox - Col. Special / Stainless Steel – Bronze – Col. Speciaux / Inox – Bronze – Sonderfarben / Rostfreier Stahl - Bronze	00010802****	10,20
	Madera – Wood – Ton Bois - Holz	00010802****	12,20
 <p>Travesero intermedio curvo Intermediate curved profile Profil intermédiaire courbe Zwischenprofil kurving</p>	Brut – Raw – Brut - Roh	000143480000	4,52
	Blanco – White – Blanc - Weiß	000143489010	5,90
	Col. Básico / Plata – Colours / Silver – Couleurs / Argent – Farben / Silber	00014348****	12,20
	Col. Especial / Bronce – Inox - Col. Special / Stainless Steel – Bronze – Col. Speciaux / Inox – Bronze – Sonderfarben / Rostfreier Stahl - Bronze	00014348****	13,00
	Madera – Wood – Ton Bois - Holz	00014348****	15,00
 <p>Perfil "Z" mosquitera corredera Sliding insect screen "Z" profile Profil "Z" moustiquaire coulissante Schiebetür Profil "Z"</p>	Brut – Raw – Brut - Roh	000038990000	2,50
	Blanco – White – Blanc - Weiß	000038999010	2,80
	Col. Básico / Plata – Colours / Silver – Couleurs / Argent – Farben / Silber	00003899****	3,00
	Col. Especial / Bronce – Inox - Col. Special / Stainless Steel – Bronze – Col. Speciaux / Inox – Bronze – Sonderfarben / Rostfreier Stahl - Bronze	00003899****	4,35
	Madera – Wood – Ton Bois - Holz	00003899****	6,56

Embalaje – Packing – Conditionnement - Verpackungseinheiten









M / barra

6,00 / 6,50

M / Box

6,00 / 6,50

DESPIECE ACCESORIOS – DETAILED ACCESSORIES . DETAIL DES ACCESSOIRES . ZUBEHÖR

	Ref.	PVP €/Und.
 <p>Soporte travesero intermedio recto para 10802 Intermediate support 10802 – Support traversier intermediaire pour 10802 – Halterung Mittelstrebe 10802</p>	OSPI0802*	0,40
 <p>Soporte travesero intermedio curvo para 14348 Intermediate support 14348 – Support traversier intermediaire pour 14348 – Halterung Mittelstrebe 14348</p>	ODP14348*	0,40
 <p>Juego escuadras corredera 4 uds (2 inf. con rodamiento + 2 superiores) Set of angles 4 units (2 lower with Wheel + 2 upper) – Jeu d'équerres roulement – Set Eckverbinder mit Rädchen</p>	ESCO1236J000*	3,50
 <p>Juego (4 uds) escuadras corredera regulable 1236C Angles (4) set regular for 1236C – Jeu d'équerres (4) réglable pour 1236C – Set (4) regulierbarer Schiebewinkel 1236C</p>	ESCOREGJ000*	6,30
 <p>Goma sujeción tejido de 6,5 mm Rubber for mesh fixation – Joint PVC 6 mm fixation toile – Keder 6 mm zur Gewebefestigung</p>	10GM60FI0002	0,40
 <p>Felpudo 5,5x6 mm 5,5x6 mm brush – Joint brisse 5,5x6 mm – Bürste 5,5x6 mm</p>	00PP55600002	0,30
 <p>Felpudo 5,5x3,5 mm 5,5x3,5 mm brush – Joint brosse 5,5x3,5 mm – Bürste 5,5x3,5 mm</p>	00PP55350002	0,20
 <p>Rodamiento corredera Ballbearing of lower angel – Roulement de l'équerre inférieure – Kugellager unterer Winkel</p>	0000RODA0002	0,70

Embalaje – Packing – Conditionnement - Verpackungseinheiten

Unidades / Caja – Units / Box

150



ABATIBLE

HINGED DOOR INSECT SCREEN
MOUSTIQUAIRE PORTE BATTANTE
INSEKTENSCHUTZ SCHWENKTÜR

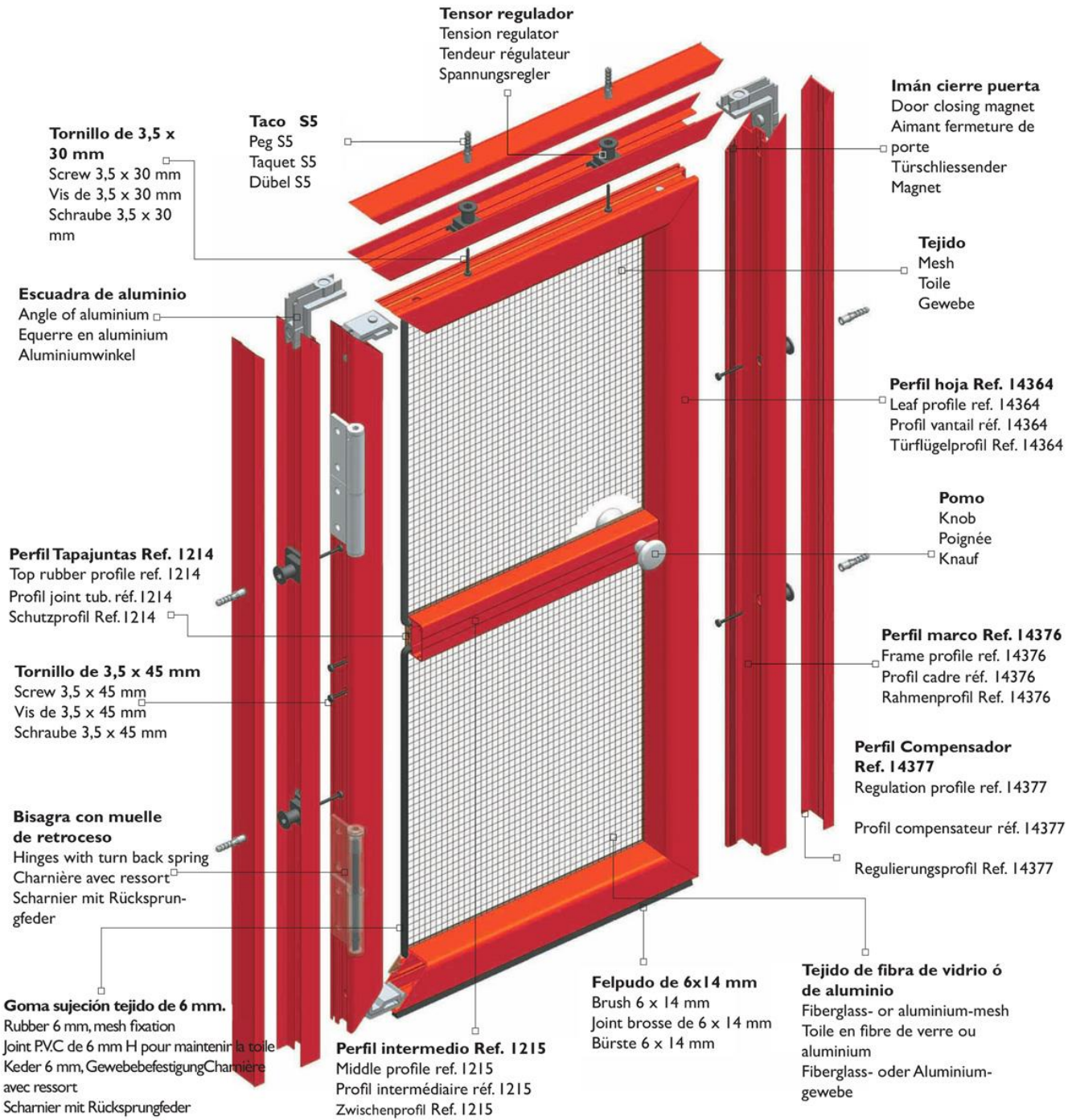

20

Sistema puerta abatible doble

Double hinged door
Système de porte battante double
Zweiflüglige Schwenktür

Bisagra con muelle de retroceso

Hinge with recoil spring
Charnière avec ressort
Scharnier mit Rückzugfeder

Sistema abatibe

Hinged door
Système porte battante
Schwenktür





PEFILES – PROFILES

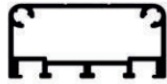

Perfil 1215 intermedio puerta abatible
1215 intermediate profile hinged door
Profil 1215 intermédiaire profil porte battante
Zwischenprofil 1215 schwenktür

	Ref.	PVP €/ml
Brut – Raw – Brut - Roh	000012150000	8,30
Blanco – White – Blanc - Weiß	000012159010	9,40
Col. Básico / Plata – Colours / Silver – Couleurs / Argent – Farben / Silber	00001215****	10,40
Col. Especial / Bronce – Inox - Col. Special / Stainless Steel – Bronze – Col. Speciaux / Inox – Bronze – Sonderfarben / Rostfreier Stahl - Bronze	00001215****	11,50
Madera – Wood – Ton Bois - Holz	00001215****	13,70



Perfil 1214 tapajuntas puerta abatible
1214 profile hidden rubber profile
Profil 1214 cache joint PVC
Profil 1214 Blende Schwenktür

Brut – Raw – Brut - Roh	000012140000	1,90
Blanco – White – Blanc - Weiß	000012149010	2,50
Col. Básico / Plata – Colours / Silver – Couleurs / Argent – Farben / Silber	00001214****	3,00
Col. Especial / Bronce – Inox - Col. Special / Stainless Steel – Bronze – Col. Speciaux / Inox – Bronze – Sonderfarben / Rostfreier Stahl - Bronze	00001214****	3,50
Madera – Wood – Ton Bois - Holz	00001214****	4,70

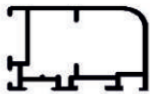

Perfil 14364 hoja puerta abatible
14364 Leaf profile hinged door small
Profil 14364 vantail porte battante petite
14364 Türflügelprofil Insektenschutz
Schwenktür klein

Brut – Raw – Brut - Roh	000014360000	8,00
Blanco – White – Blanc - Weiß	000014369010	9,15
Col. Básico / Plata – Colours / Silver – Couleurs / Argent – Farben / Silber	00001436****	10,20
Col. Especial / Bronce – Inox - Col. Special / Stainless Steel – Bronze – Col. Speciaux / Inox – Bronze – Sonderfarben / Rostfreier Stahl - Bronze	00001436****	11,30
Madera – Wood – Ton Bois - Holz	00001436****	13,70

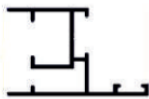

Perfil 14376 marco puerta abatible
14376 Frame profile hinged door small
Profil 14376 cadre porte battante petite
14376 Rahmenprofil Insektenschutz
Schwenktür klein

Brut – Raw – Brut - Roh	0000143760000	6,80
Blanco – White – Blanc - Weiß	0000143769010	7,80
Col. Básico / Plata – Colours / Silver – Couleurs / Argent – Farben / Silber	000014376****	8,80
Col. Especial / Bronce – Inox - Col. Special / Stainless Steel – Bronze – Col. Speciaux / Inox – Bronze – Sonderfarben / Rostfreier Stahl - Bronze	000014376****	9,70
Madera – Wood – Ton Bois - Holz	000014376****	11,80



Perfil 14377 compensador puerta abatible
14377 Regulation profile hinged door
Profil 14377 compensateur porte battante petite
14377 Regulierungsprofil Insektenschutz
Schwenktür klein

Brut – Raw – Brut - Roh	0000143770000	1,80
Blanco – White – Blanc - Weiß	0000143779010	2,40
Col. Básico / Plata – Colours / Silver – Couleurs / Argent – Farben / Silber	000014377****	3,00
Col. Especial / Bronce – Inox - Col. Special / Stainless Steel – Bronze – Col. Speciaux / Inox – Bronze – Sonderfarben / Rostfreier Stahl - Bronze	000014377****	3,50
Madera – Wood – Ton Bois - Holz	000014377****	4,60



Perfil 1220 intermedio puerta abatible doble
1220 intermediate profile hinged door
Profil 1220 intermédiaire profil porte battante
Zwischenprofil 1220 Schwenktür

Brut – Raw – Brut - Roh	000012200000	2,90
Blanco – White – Blanc - Weiß	000012209010	3,50
Col. Básico / Plata – Colours / Silver – Couleurs / Argent – Farben / Silber	00001220****	4,00
Col. Especial / Bronce – Inox - Col. Special / Stainless Steel – Bronze – Col. Speciaux / Inox – Bronze – Sonderfarben / Rostfreier Stahl - Bronze	00001220****	4,55
Madera – Wood – Ton Bois - Holz	00001220****	5,70

Embalaje – Packing – Conditionnement - Verpackungseinheiten

M / barra

5,50 / 6,00 / 6,40

M / Box

55 / 60 / 64



DESPIECE ACCESORIOS – DETAILED ACCESSORIES . DETAIL DES ACCESSOIRES . ZUBEHÖR	Ref.	PVP €/Und.
Goma burlete 6 mm (250 mts rollo) 6 mm Rubber – Joint PVC 6 mm – Keder 6 mm	000PAGMH0002	0,40
Felpudo polypile 6x14 mm 6x14 mm mm brush – Joint brisse 6x14 mm – Bürste 6x14 mm	00PP60140002	0,40
Imán bipolar puerta abatible Magnet for closing System – Aimant bipolaire fermeture – Bipolar Magnet für Schwenktür	00PAIMOS0002	1,40
Juego escuadra puerta abatible (4 hoja + 2 marco) Upper hinged door insect screen– Equerre moustiquaire porte battante– Scharniertürhalterung	00PAESHO 00PAESMA	17,60
Kit puerta abatible Kit hinged door small – kit porte battante petite – Zubehör Schwenktür klein	0000KPAP0002	60,00
Kit puerta abatible doble Kit double-hinged door small – kit porte battante double petite – Zubehör doppelte Schwenktür klein	00KPAPDB0002	120,00
Bisagra puerta abatible mini con muelle negro Hinged door hinge with black spring – Charmière porte battante avec resort noir – Schwenktür mit schwarzer feder	BSPAPMMU0002	20,00
Bisagra puerta abatible mini sin muelle negro Hinged door hinge without black spring – Charmière porte battante sans resort noir – Schwenktür ohne schwarzer feder	BSPAPMSM0002	17,00

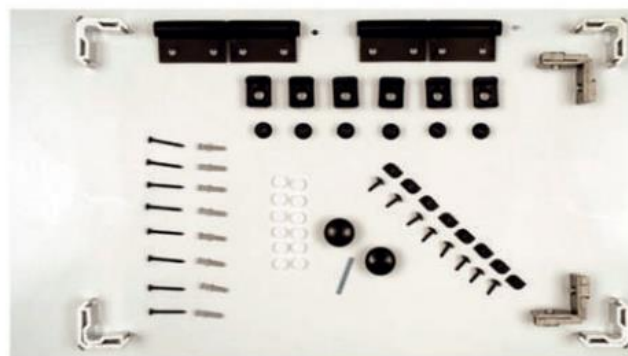

Troqueladoras
Punching machines - Poinçonneuse - Stanzmaschinen

Máquina troquelar puerta abatible

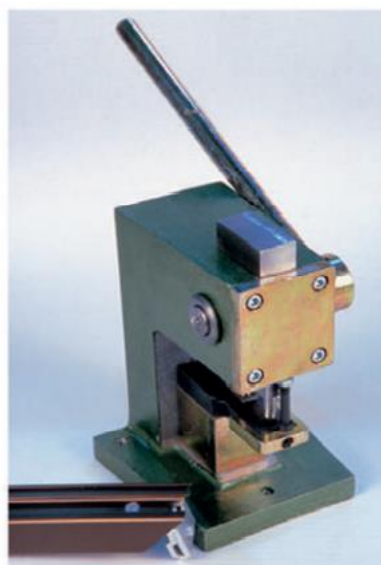

MANUAL

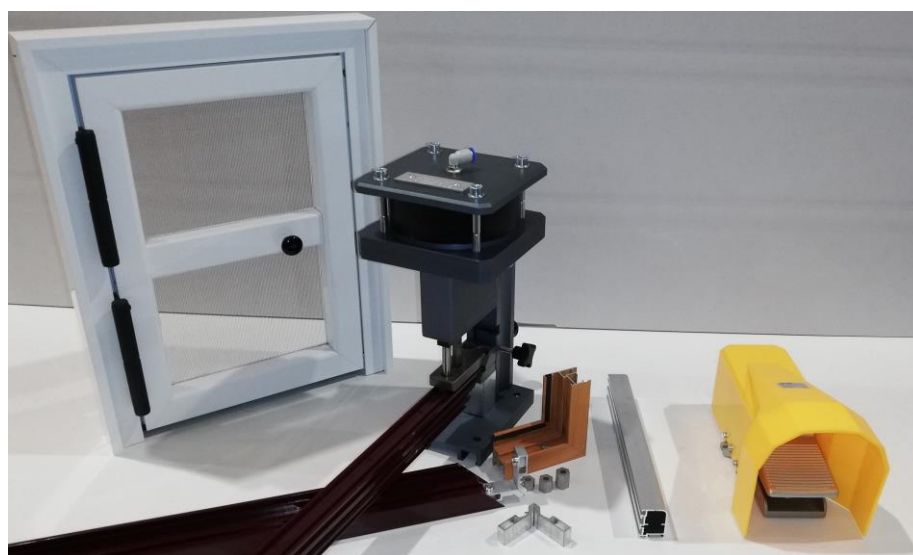

NEUMÁTICA

1.200 €
NETO



PRICE LIST
LISTE DE PRIX
PREISLISTE

INSECT SCREEN MESH ROLLS
ROULEAUX DE TOILE MOUSTIQUAIRE
ROLLEN INSEKTENSCHUTZGEWEBE

ROLLOS MOSQUITERA

INSECT SCREEN MESH – ROLLSROULEAUX DE TOILE MOUSTIQUAIRE – ROLLEN INSEKTENSCHUTZGEWEBE



ROLLO FIBERGLAS 30 mts

ROLL FIBERGLAS 30 mts – ROLEAU FIBERGLAS 30 mts – ROLLE GEWEBE FIBERGLAS 30 mts

	Ref.	PVP €/Und.
Rollo 0,60 x 30 m – 0,6 x 30 m Roll	TEMO06300000	38,40
Rollo 0,8 x 30 m – 0,8 x 30 m Roll	TEMO08300000	51,15
Rollo 1,00 x 30 m – 1,00 x 30 m Roll	TEMO10300000	65,00
Rollo 1,20 x 30 m – 1,20 x 30 m Roll	TEMO12300000	76,70
Rollo 1,50 x 30 m – 1,50 x 30 m Roll	TEMO15300000	96,00

ROLLOS MOSQUITERA

INSECT SCREEN MESH – ROLLSROULEAUX DE TOILE MOUSTIQUAIRE – ROLLEN INSEKTENSCHUTZGEWEBE



ROLLO DE ALUMINIO 30 mts

ALUMINIUM ROLL 30 mts – ROLEAU D'ALUMINIUM 30 mts – ALUMINIUMROLLE 30 mts

	Ref.	PVP €/Und.
Rollo 1,00 x 30 m – 1,00 x 30 m Roll	ATEMI03000000	170,00
Rollo 1,20 x 30 m – 1,20 x 30 m Roll	ATEMI23000000	205,00
Rollo 1,50 x 30 m – 1,50 x 30 m Roll	ATEMI03000000	255,00

TUBO CON TELA FIBERGLAS

TUBE WITH MESH FIBERGLAS – TUBE AVEC TISSU FIBERGLAS – ROHR MIT GEWEBE FIBERGLAS



Tubo con tela 140/R33

Tube with mesh 140/R33 – Tube avec tissu 140/R33 – Rohr mit gewebe 140/R33

TETU14600000 9,60

Tubo con tela 180/R35

Tube with mesh 180/R35 – Tube avec tissu 180/R35 – Rohr mit gewebe 180/R35

TETU141860000 10,00

Tubo con tela 180

Tube with mesh 180 – Tube avec tissu 180 – Rohr mit gewebe 180

TETU186000000 11,00

Tubo con tela 240

Tube with mesh 240 – Tube avec tissu 240 – Rohr mit gewebe 240

TETU246000000 12,00

Embalaje – Packing – Conditionnement - Verpackungseinheiten

M / barra

6

M / Box

36 / 48





TARIFA DE PRECIOS

MOSQUITERA A MEDIDA

PRICE LIST
LISTE DE PRIX
PREISLISTE

INSECT SCREEN ON MEASUREMENT
MOUSTIQUAIRE SUR MESURE
INSEKTENSCHUTZ NACH MAB

MOSQUITERA ENROLLABLE VERTICAL P42 – R33 – R35

VERTICAL ROLLER INSECT SCREEN - MOUSTIQUAIRE ENROULABLE VERTICALE - VERTIKALES INSEKTENSCHUTZ ROL

Blanco – White / Blanc / Weiß

Ancho / Width Alto / Height	80	90	100	110	120	130	140	150	160	170	180	190	200	210	220
80	51	53	57	59	62	64	66	70	72	75	77	79	83	87	90
100	53	57	59	62	64	66	70	72	75	77	79	83	85	90	92
120	57	59	62	64	66	70	72	75	77	80	83	85	88	92	95
140	59	62	64	67	70	72	75	77	80	83	85	88	90	95	98
160	62	64	67	70	72	75	77	80	83	85	88	90	93	98	100
180	68	70	73	76	79	81	84	88	90	93	96	99	101	106	109
200	70	73	76	79	81	84	87	90	93	96	99	101	104	109	112
220	72	76	79	81	84	87	90	92	96	99	101	104	107	112	114
230	74	77	80	82	86	89	91	94	97	100	102	106	108	113	116

Color básico / Plata – Colours / Silver– Couleurs / Argent – Farben / Silber

Ancho / Width Alto / Height	80	90	100	110	120	130	140	150	160	170	180	190	200	210	220
80	54	57	60	62	65	67	71	74	76	79	82	85	87	92	95
100	57	60	62	65	68	71	74	76	79	82	85	88	90	95	98
120	60	63	65	68	71	74	76	79	83	85	88	90	93	98	101
140	63	65	68	71	74	77	79	83	85	88	90	93	97	101	104
160	65	68	72	74	77	79	83	85	88	91	93	97	99	104	106
180	71	74	78	81	83	87	90	93	96	99	102	106	108	113	116
200	74	78	81	83	87	90	93	96	99	102	106	108	111	116	119
220	78	81	83	87	90	93	96	99	102	106	108	111	114	120	122
230	79	82	86	89	91	94	98	100	103	107	110	112	116	121	124

Color Especiales / Inox / Bronce - Colours Special / Stainless / Bronze– Couleurs Spéciaux / Inox / Bronze – Farben Sonderfarben / Rostfreier Stahl / Bronze

Ancho / Width Alto / Height	80	90	100	110	120	130	140	150	160	170	180	190	200	210	220
80	59	62	65	68	72	75	78	82	85	87	90	93	97	102	105
100	64	65	68	72	75	78	82	85	88	91	95	97	100	105	109
120	67	70	73	76	78	82	85	88	91	95	98	101	104	109	112
140	72	73	76	79	83	86	88	91	95	98	101	104	108	113	116
160	75	76	79	83	86	89	92	96	99	101	104	108	111	116	119
180	82	83	87	90	93	97	100	103	107	111	114	118	121	126	130
200	86	87	90	93	98	101	104	108	111	114	118	121	124	130	133
220	89	91	94	98	101	104	108	111	114	118	121	124	128	133	136
230	90	92	96	99	102	107	110	113	117	120	123	127	130	135	139

Madera – Wood– Ton Bois- Holz

Ancho / Width Alto / Height	80	90	100	110	120	130	140	150	160	170	180	190	200	210	220
80	71	75	78	83	65	90	95	99	102	107	110	114	118	124	128
100	78	79	84	88	91	96	99	103	108	111	115	120	123	129	132
120	83	85	88	92	97	100	104	109	112	116	120	124	128	134	138
140	88	89	93	98	101	105	109	113	117	121	125	129	133	139	142
160	92	95	98	102	107	110	114	118	122	126	129	134	138	143	148
180	101	103	108	111	112	120	124	129	132	137	141	146	150	155	160
200	107	108	112	117	121	126	129	133	138	142	146	150	154	161	165
220	111	113	118	121	126	130	134	139	142	147	151	156	160	165	170
230	114	116	120	124	129	132	137	141	146	149	153	158	162	169	172



TARIFA DE PRECIOS

MOSQUITERA A MEDIDA

PRICE LIST
LISTE DE PRIX
PREISLISTE

INSECT SCREEN ON MEASUREMENT
MOUSTIQUEAIRE SUR MESURE
INSEKTENSCHUTZ NACH MAB



MOSQUITERA ENROLLABLE PUERTA LATERAL

LATERAL DOOR SYSTEM

SYSTÈME DE PORTE LATÉRALE

INSEKTENSCHUTZ ROLLO EINZELSEINTENTÜR

PUERTA DOBLE LATERAL

DOUBLE LATERAL DOOR SYSTEM

SYSTÈME DE PORTE LATÉRALE DOUBLE

DOPPELSEINTENTÜR



Blanco - White / Blanc / Weiß

Ancho / Width Alto / Height	80	100	110	120	140	160	180	200	220
160	86	88	89	135	137	139	141	143	147
170	89	91	92	140	142	145	147	149	152
180	92	94	96	146	148	150	152	154	157
190	96	98	99	151	153	155	158	160	163
200	99	101	102	157	159	161	163	165	168
210	102	104	106	162	164	166	168	171	175
220	106	108	109	167	170	172	174	177	180
230	109	111	112	173	175	177	179	183	186

Color básico / Plata - Colours / Silver- Couleurs / Argent - Farben / Silber

Ancho / Width Alto / Height	80	100	110	120	140	160	180	200	220
160	91	93	94	142	145	148	150	152	156
170	94	97	98	149	151	153	155	159	163
180	98	100	101	154	157	159	162	164	168
190	101	103	104	160	163	165	167	170	175
200	104	107	109	166	168	171	173	176	180
210	108	111	112	172	174	176	179	182	186
220	112	114	116	177	180	183	185	187	192
230	116	118	119	184	186	188	190	193	198

Color Especiales / Inox / Bronce - Colours Special / Stainless / Bronze- Couleurs Spéciaux / Inox / Bronze - Farben Sonderfarben / Rostfreier Stahl / Bronze

Ancho / Width Alto / Height	80	100	110	120	140	160	180	200	220
160	100	102	104	157	160	163	166	168	174
170	103	107	108	163	166	170	173	175	180
180	108	110	112	170	173	176	179	182	187
190	111	114	116	176	179	183	186	188	193
200	116	119	120	183	186	189	192	195	200
210	119	122	123	189	192	196	199	201	206
220	123	127	128	196	199	202	205	208	213
230	128	130	132	202	205	209	212	214	219

Madera- Wood- Ton Bois- Holz

Ancho / Width Alto / Height	80	100	110	120	140	160	180	200	220
160	120	124	127	189	193	198	201	205	207
170	126	129	131	198	201	205	210	214	216
180	130	134	137	205	210	214	217	222	224
190	134	139	141	214	217	222	226	230	232
200	140	144	146	222	226	230	234	238	240
210	144	149	151	230	234	238	242	247	249
220	150	154	156	238	242	246	250	254	256
230	154	166	161	246	250	254	259	262	264



TARIFA DE PRECIOS

MOSQUITERA A MEDIDA

PRICE LIST
LISTE DE PRIX
PREISLISTE

INSECT SCREEN ON MEASUREMENT
MOUSTIQUAIRE SUR MESURE
INSEKTENSCHUTZ NACH MAB

MOSQUITERA FIJA

FIXED INSECT SCREEN - MOUSTIQUAIRE FIXE - SPANNRAHMEN



Blanco - White / Blanc / Weiß

Ancho / Width Alto / Height	40	50	60	70	80	90	100	110	120	130	140	150
80	41	43	45	46	48	49	50	52	53	55	57	58
100	42	45	46	48	49	51	52	53	55	57	59	60
120	45	46	48	49	50	52	53	55	57	59	60	62
140	46	47	49	50	52	53	55	57	59	61	62	64
160	47	48	50	52	53	55	57	59	61	62	64	65
180	48	50	51	53	55	57	59	61	62	64	65	67
200	49	51	53	54	57	59	60	62	64	65	67	70
220	50	52	54	57	58	60	62	64	65	67	70	72

Color básico / Plata - Colours / Silver- Couleurs / Argent - Farben / Silber

Ancho / Width Alto / Height	40	50	60	70	80	90	100	110	120	130	140	150
80	42	45	46	48	49	51	52	54	55	58	59	60
100	45	46	48	49	51	52	54	55	58	59	61	62
120	46	47	49	51	52	54	55	58	59	61	63	64
140	47	49	50	52	54	55	58	60	61	63	64	66
160	48	50	52	53	55	58	59	61	63	65	66	68
180	50	51	53	55	58	59	61	63	65	66	68	71
200	51	53	54	57	59	61	63	64	66	68	71	73
220	52	54	57	59	60	62	64	66	68	71	73	74

Color Especiales / Inox / Bronce - Colours Special / Stainless / Bronze- Couleurs Spéciaux / Inox / Bronze - Farben Sonderfarben / Rostfreier Stahl / Bronze

Ancho / Width Alto / Height	40	50	60	70	80	90	100	110	120	130	140	150
80	46	47	49	50	52	54	55	58	60	61	63	65
100	47	49	50	52	54	55	58	60	62	63	65	67
120	48	50	52	54	55	58	60	62	63	65	67	70
140	50	52	53	55	58	60	62	63	65	67	70	72
160	51	53	55	58	60	62	63	65	67	70	72	74
180	53	55	58	59	61	63	65	67	70	72	74	76
200	54	57	59	61	63	65	67	70	72	74	76	78
220	57	59	61	63	65	67	70	72	74	76	78	80

Madera - Wood - Ton Bois - Holz

Ancho / Width Alto / Height	40	50	60	70	80	90	100	110	120	130	140	150
80	50	53	55	58	60	62	64	66	68	71	73	75
100	52	54	58	60	62	64	66	68	71	73	75	77
120	54	57	59	62	64	66	68	71	73	76	78	80
140	57	59	61	64	66	68	71	73	76	78	80	83
160	59	61	63	66	68	71	73	76	78	80	84	86
180	61	63	65	68	71	73	76	78	80	84	86	88
200	62	65	67	71	73	75	78	80	84	86	88	91
220	64	67	70	73	75	77	80	83	86	88	91	93

ESPECIFICACIONES: SPECIFICATIONS - CARACTÉRISTIQUES - SPEZIFIKATIONEN

MOSQUITERA FIJA EN "KIT": Sin montaje del tejido, con todos los componentes y aluminio cortado y troquelado.

FIXED INSECT SCREEN KIT: Without assembling the mesh, with all of the components and cut to size and die cutting aluminium.

MOUSTIQUAIRE FIXE KIT: Sans assemblage du tissu, avec tous les composants et aluminium coupé et perforé.

SPANNRAHMENKIT: Ohne montage des gewebes, mit allen komponenten und zugeschnittenem und gestanztem.

-10 €
NETO



MOSQUITERA FIJA OJO DE BUEY
PORTHOLE FIXED INSECT SCREEN
MOUSTIQUAIRE FIXE RONDE
RUNDS FESTES MOSKITONETZ.

+60 €
NETO



MOSQUITERA FIJA MEDIO PUNTO
PORTHOLE FIXED INSECT SCREEN
MOUSTIQUAIRE FIXE RONDE
RUNDS FESTES MOSKITONETZ.

+60 €
NETO



TARIFA DE PRECIOS

MOSQUITERA A MEDIDA

PRICE LIST
LISTE DE PRIX
PREISLISTE

INSECT SCREEN ON MEASUREMENT
MOUSTIQUAIRE SUR MESURE
INSEKTENSCHUTZ NACH MAB

MOSQUITERA CORREDERA 1236C

SLIDING INSECT SCREEN 1236C - MOUSTIQUAIRE COULISSANTE 1236 - INSEKTENSCHUTZ SCHIEBETÜR 1236C



Blanco - White / Blanc / Weiß

Ancho / Width Alto / Height	40	50	60	70	80	90	100	110	120	130	140	150
80	49	51	52	54	57	59	61	63	64	66	68	71
100	52	54	57	59	61	63	65	67	70	71	73	75
120	55	58	60	62	64	66	70	72	74	76	78	80
140	59	62	64	66	68	71	73	76	78	80	83	85
160	63	65	67	71	73	75	77	80	83	85	87	90
180	66	68	72	74	76	79	82	85	87	89	92	95
200	70	73	75	78	80	84	86	89	91	93	97	99
220	73	76	79	82	85	87	90	93	96	99	101	104

Color básico / Plata - Colours / Silver- Couleurs / Argent - Farben / Silber

Ancho / Width Alto / Height	40	50	60	70	80	90	100	110	120	130	140	150
80	51	53	55	58	60	62	64	66	67	70	72	74
100	54	57	59	61	64	66	68	71	73	75	77	79
120	59	61	63	65	67	71	73	75	77	79	83	85
140	62	65	67	70	72	75	77	79	83	85	87	90
160	66	68	72	74	76	79	82	85	87	90	92	95
180	70	73	75	78	80	84	86	89	92	95	98	100
200	74	76	79	83	85	88	91	93	97	100	102	105
220	77	80	84	87	89	92	96	99	101	104	108	111

Color Especiales / Inox / Bronce - Colours Special / Stainless / Bronze- Couleurs Spéciaux / Inox / Bronze - Farben Sonderfarben / Rostfreier Stahl / Bronze

Ancho / Width Alto / Height	40	50	60	70	80	90	100	110	120	130	140	150
80	54	57	60	62	64	67	70	72	74	77	79	82
100	59	62	64	66	70	72	75	77	79	83	85	88
120	63	66	68	72	74	77	79	83	85	88	90	93
140	68	71	74	76	79	83	85	88	90	93	97	99
160	73	75	78	82	84	88	90	93	96	99	102	104
180	77	80	83	86	89	92	96	98	101	104	108	111
200	82	85	88	91	95	98	100	103	107	110	113	116
220	86	89	92	96	99	102	105	109	112	115	118	122

Madera- Wood- Ton Bois- Holz

Ancho / Width Alto / Height	40	50	60	70	80	90	100	110	120	130	140	150
80	63	66	70	73	76	79	83	86	89	92	96	98
100	70	73	76	79	83	86	89	92	96	99	102	105
120	75	78	82	85	89	92	96	99	102	105	110	113
140	80	85	88	91	96	99	102	105	110	113	116	120
160	87	90	95	98	101	105	109	113	116	120	124	127
180	92	97	100	104	108	112	115	120	123	127	130	135
200	99	102	107	111	114	118	122	126	130	134	138	141
220	104	109	113	116	121	125	128	133	137	141	145	149

ESPECIFICACIONES: SPECIFICATIONS - CARACTÉRISTIQUES - SPEZIFIKATIONEN

**Para medidas superiores a 120 cm (ancho/alto) hay que incluir un travesaño

For measurements superior to 120 cm (width/height) it is necessary to include a cross brace

Pour des mesures supérieures à 120 cm (largeur/hauteur) il faut inclus la traversière.

Bei Abmessungen die 120 cm (Breite/Höhe) überschreiten muss eine traverse eingetzt werden gerne erstellen

+5€ NETO

MOSQUITERA CORREDERA EN "KIT": Sin montaje del tejido, con todos los componentes y aluminio cortado y troquelado.

SLIDING INSECT SCREEN KIT: Without assembling the mesh, with all of the components and cut to size and die cutting aluminium.

MOUSTIQUAIRE COULISSANTE KIT: Sans assemblage du tissu, avec tous les composants et aluminium coupé et perforé.

SCHIEBETÜR KIT: Ohne montage des gewebes, mit allen komponenten und zugeschnittenem und gestanztem.

-15 € NETO



TARIFA DE PRECIOS

MOSQUITERA A MEDIDA

PRICE LIST
LISTE DE PRIX
PREISLISTE

INSECT SCREEN ON MEASUREMENT
MOUSTIQUAIRE SUR MESURE
INSEKTENSCHUTZ NACH MAB



MOSQUITERA PUERTA ABATIBLE

HINGED DOOR INSECT SCREEN
MOUSTIQUAIRE PORTE BATTANTE
INSEKTENSCHUTZ SCHWENKTÜR

****SUPLEMENTO TELA METÁLICA COMPLETA 40€ NETO**

****SUPLEMENTO TELA METÁLICA ½ PUERTA 20€ NETO**

****SUPLEMENTO TRAVESAÑO EXTRA 6€ NETO**



Blanco – White / Blanc / Weiß

Ancho / Width Alto / Height	60	70	80	90	100	110	120
180	265	268	270	275	280	290	295
190	270	275	278	280	285	295	298
200	275	280	285	285	290	298	300
210	283	285	286	290	295	300	341
220	290	295	297	298	300	341	379
230	295	298	300	305	375	378	385
240	300	305	324	376	379	380	388
250	322	323	375	380	385	390	392

Color básico / Plata – Colours / Silver– Couleurs / Argent – Farben / Silber

Ancho / Width Alto / Height	60	70	80	90	100	110	120
180	275	278	280	283	290	295	301
190	278	280	283	285	295	298	305
200	280	283	285	290	298	300	310
210	285	290	295	298	300	305	357
220	290	296	298	305	308	357	390
230	295	298	300	310	390	395	400
240	300	305	339	390	395	400	405
250	337	338	394	396	400	411	412

Color Especiales / Inox / Bronce - Colours Special / Stainless / Bronze– Couleurs Spéciaux / Inox / Bronze – Farben Sonderfarben / Rostfreier Stahl / Bronze

Ancho / Width Alto / Height	60	70	80	90	100	110	120
180	288	290	295	297	308	310	315
190	290	295	298	300	310	315	320
200	295	298	300	305	315	320	325
210	304	305	307	308	320	325	371
220	305	306	310	310	325	370	415
230	308	310	312	315	413	415	420
240	310	315	352	412	418	420	425
250	349	351	411	420	425	428	430

Madera – Wood– Ton Bois- Holz

Ancho / Width Alto / Height	60	70	80	90	100	110	120
180	338	340	345	348	355	360	362
190	340	345	348	350	360	365	368
200	348	350	352	355	362	368	370
210	350	352	353	358	365	370	440
220	354	355	357	360	368	440	498
230	356	358	360	365	490	495	500
240	358	360	415	495	497	498	510
250	412	414	494	500	505	517	520



PRICE LIST
LISTE DE PRIX
PREISLISTE

ACCESSORIES
ACCESSOIRES
ZUBEHÖR

MOSQUITERA PUERTA ABATIBLE

HINGED DOOR INSECT SCREEN - MOUSTIQUAIRE PORTE BATTANTE - INSEK TENSCHUTZ SCHWENKTÜR

MOSQUITERA ABATTIBLE EN "KIT": Sin montaje del tejido, con todos los componentes y aluminio cortado y troquelado.

-40 € NETO

HINGED INSECT SCREEN KIT: Without assembling the mesh, with all of the components and cut to size and die cutting aluminium.

MOUSTIQUAIRE BATTANTE KIT: Sans assemblage du tissu, avec tous les composants et aluminium coupé et perforé.

INSEKTENSCHUTZ SCHWENKTÜR KIT: Ohne montage des gewebes, mit allen komponenten und zugeschnittenem und gestanztem.

Gateras

Gatera con frontal fijo extraíble.

Medidas L: 35x29x4cm - Peso: 870g
Medida XL: 43x35,5x4cm - Peso: 1,24kg

Gatera para Fijación en tela mosquitera.

Medida L: 24x29x1cm - Peso: 345g
Medias XL: 37x42x1cm - Peso: 650g

PUERTA CON CHAPA INF.

GAT135294		Colores: Blanco/Negro Medidas: 35x29x4cm Peso: 870g	43.20 € NETO
GAT143354		Colores: Blanco/Negro Medidas: 43x35,5x4cm Peso: 1,24kg	57.50 € NETO
GAT224291		Medidas: 24x29x1cm Peso: 345g	25.45 € NETO
GAT237421		Medidas: 37x42x1cm Peso: 650g	42.37 € NETO

BLANCO - PLATA
WHITE - SILVER
BLANC - ARGENT
WEISS - SILBER

+ 45€ netos

COLORES BÁSICOS
STANDARD COLOURS
COULEURS STANDARDS
STANDARDFARBEN

+ 55€ netos

COLORES ESPECIALES
SPECIAL COLOURS
COULEURS SPECIALES
SONDERFARBEN

+ 65€ netos

BRONCE
BRONZE
BRONZE
BRONZE

+ 80€ netos

MADERAS
WOODS
BOIS
HOLZ

+ 95€ netos

MUESTRAS PARA MOSQUITERAS CON PREMARCO Y MANETA PARA TRANSPORTAR

SAMPLE FOR INSECT SCREEN WITH PRE-FRAME AND TRANSPORT HANDLE

ÉCHANTILLONS POUR MOUSTIQUAIRES AVEC CADRE ET POIGNÉE POUR TRANSPORTER

MUSTER FÜR INSEKTENSCHUTZ MIT RAHMEN UND TRAGEGRIFFF



ENROLLABLE / ROLLER - ENROULABLE - ROLLO

30 € NETO



ABATIBLE / HINGED DOOR - PORTE BATTANTE - SCHWENKTÜR

50 € NETO



ACABADOS

FINISHES
FINITIONS
ANFERTIGUNGEN

Ofrecemos una amplia gama de acabados para todos nuestros productos, lacados de la carta Ral, Anodizados, Inox e imitación maderas.

We offers a great range of finishes for all our products, lacquering from Ral-colours, anodized, stainless and Wood imitation.

Vous offre une large gamme de finitions pour nos produits, laqués dans les couleurs de la carte Ral. Anodisés, inox et faux-bois.

Bietet eine breite Palette verschiedenster Anfertigungen, Lackierungen in Ral-Farben, eloxiert, Edelstahl oder Holzimitation an.

Colores básicos; plazo de producción de 15 días.
Los colores de estos acabados son orientativos y pueden tener diferencias con los originales.

Standard colours; delivery time: 15 days.
The colours of these finishes are approximate and there may have differences with the originals.

Couleurs standards; délai de fabrication: 15 jours.
Ces couleurs restent orientatives et il peut y avoir une différence avec les couleurs originales.

Standardfarben; Lieferzeit 15 Tage.
Diese Farben sind orientativ und können vom Original abweichen.

COLORES BÁSICOS - STANDARD COLOURS - COULEURS STANDARDS - STANDARDFARBEN

3005	7022 *	9001 *
5010	7035 *	9005 *
6005 *	8007 *	9011
6009 *	8014 *	9016
7011 / 7012 *	8017 *	1015
7016 *	8019 *	—

BLFR Blanco frances - French white - Blanc Français - französisches weiß
GRGR Gris grafito - Grey graphite - Gris graphite - Grauer Graphit

(*) COLORES BÁSICOS EN STOCK

COLORES ESPECIALES - SPECIAL COLOURS - COULEURS SPECIALES - SONDERFARBEN

1013	1000	3004	5008 MATE	6014	7005	7024	7045
3007	1001	3009	5009	6015	7006	7026	7046
5002	1002	3012	5011	6019	7008	7031	7047
5013	1011	3015	5012	6021	7009	7032	8000
6002	1019	3022	5015	6024	7012	7038	8001
—	1020	4003	5018	6025	7013	7033	8003
—	1024	4005	5019	6026	7015	7039	8019 MATE
—	1034	4009	6000	6028	7021	7040	8025
—	3000	5000	6004	7000	7022 MATE	7043	8028
—	3003	5003	6013	7004	7023	7044	9002
—	1003	1016	1032	2004	3002	3020	4008
—	1004	1017	1035	2008	3011	3027	4011
—	1006	1018	1036	2011	3013	4001	5008
—	1007	1021	2000	2012	3016	4002	5026
—	1012	1023	2002	2013	3017	4004	6022
—	1014	1028	2003	3001	3018	4006	7048

5001 - 5004 - 5005 - 5007 - 5014 - 5015 MATE - 5017 - 5020 - 5021 - 5022 - 5023 - 5024 - 6001 - 6003 - 6007 - 6009 MATE - 6008
6010 - 6011 - 6016 - 6017 6018 - 6020 - 6029 - 6032 - 6033 - 6034 - 6109 - 7001 - 7003 - 7010 - 7012 MATE - 7015 MATE - 7030
7024 MATE - 7034 - 7036 - 7037 - 7311 - 8002 - 8004 - 8008 - 8011 - 8012 - 8014 MATE - 8015 - 8016 - 8022 - 8023 - 8024 - 9003
9016 MATE - 9018 - PERGAMON - VISON

3002 MATE - 3805 - 5013 MATE - 7137 - 7179 - 7811 - 7815 - 8014 MARRON DE INDE - 8029 - 8102 - 8109 - 8910 - 9006 - 9007
9811 - 9914 - 9022 - 9023 - BLANCO MATE - GAMA SABLES - DA 33 LD150 - NEGRO ALBINO 903

Colores especiales; plazo de producción de 15 a 20 días.
Los colores de estos acabados son orientativos y pueden tener diferencias con los originales.
Los colores que no encuentren en estas tablas se realizarán bajo presupuesto.
Incremento en colores especiales para cantidades inferiores a 40 barras de 100€ netos (forfait).
Los pedidos superiores a 40 barras en colores especiales y especiales I, no llevan incremento.

Special colours; delivery time from 15 to 20 days.
The colours of these finishes are approximate and there may have differences with the originals.
The colours that are not on these charts, will be made on budget.
For the special colours, there will be an additional fixed price of €100.
For orders of more than 40 lengths, the additional fixed price will not be applicable.

Couleurs speciales; délai de fabrication de 15 à 20 jours.
Ces couleurs restent orientatives et il peut y avoir une différence avec les couleurs originales.
Les couleurs qui ne se trouvent pas dans ces tableaux devront être calculées sous devis.
Forfait couleur spéciale 100 €. Les commandes de plus de 40 barres n'auront pas de forfait.

Sonderfarben; Lieferzeit 15 bis 20 Tage.
Diese Farben sind orientativ und können vom Original abweichen.
Die Farben die nicht in diesen Tabellen sind, werden auf Budget gemacht.
Für spezielle Farben, gibt es ein Pauschalebetrug von € 100.
Für Bestellungen von über 40 Längen, wird der Pauschalebetrug nicht zugesagt.



ACABADOS

FINISHES
FINITIONS
ANFERTIGUNGEN

ACABADOS EN MADERA - WOOD FINISHES - FINITIONS EN FAUX - BOIS - ANFERTIGUNGEN IN HOLZ

COLORES BÁSICOS EN STOCK



PINU - PINO NUDO
PINE KNOT



NOOS-NOGAL OSCURO
DARK WALNUT -
NOYER FONCÉ -
DUNKLE WALNUß



NOAN-NOGAL ANDALUZ
DARK WALNUT -
NOYER FONCÉ -
DUNKLE WALNU



EMBERO - EMBERO



ROGO - ROBLE GOLDEN
GOLDEN OAK

OTRAS MADERAS



SACA - SAPELLY CAOBA
MAHOAGANY



DOG8 - DOUGLAS
RUCE, DOUGLASWOOD



TEKA - TEKA
TEAK



CECA - CEREZO
CON CATEDRALES
CHERRY



SABU - SAPELLY BURDEOS
SAPELLY BURGUNDY

OTRAS MADERAS - OTHER WOODS FINISHES
AUTRES FAUX - BOIS - ANDERE HOLZTÖNE

ROAS

Roble assi - Assi Oak - Chêne assi - Eiche assi

TEKT

Teka texturado - Textured Teak - Tek texturé -
Teka Gewebe

FOLIADOS - FOLIATED - FOLIE - FOLIERT



EMBERO -
ROBLE DORADO



NOGAL -
NUSS BAUM

Acabados en imitación maderas; plazo de producción de 20 días.

Wood finishes; delivery time: 20 days.
Finitions en Faux-bois; délai de fabrication: 20 jours.
Anfertigungen in Holzimitationen; Lieferzeit: 20 Tage.

Posibilidad de realizar acabados especiales, consultar.

Special finishes, on request.
Finitions spéciales possibles, consulter.
Sonderanfertigungen laut Anfrage.

ANODIZADOS - ANODIZED FINISHES - / .NODISÉS - ELOXIERTE ANFERTIGUNGEN



REF: 0040

INOX.
STAINLESS STEEL
INOX
ROSTFREIER STAHL

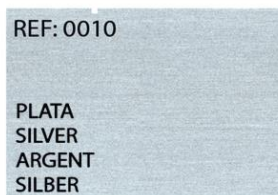

REF: 0010

PLATA
SILVER
ARGENT
SILBER



REF: 0020

BRONCE
BRONZE
BRONZE
BRONZE



REF: 0030

ORO
GOLD
OR
GOLD

INOX - BRONCE - ORO = TARIFA COLESPECIALES

PLATA = TARIFA BLANCO / PLATA

STAINLESS STEEL - BRONZE - GOLD = SPECIAL COLOUR TARIFF

SILVER = TARIFF WHITE/SILVER

INOX - BRONZE - OR = TARIFF COULEURS SPECIALES

ARGENT = TARIFF BLANC / ARGENT

ROSTFREIER STAHL - BRONZE - GOLD = TARIFF SONDERFARBEN

SILBER = TARIFFPREIS WEIß/SILBER

Anodizados; plazo de producción de 10 días.

Anodized finishes; delivery time: 10 days.

Anodisés; délai de fabrication : 10 jours.

Eloxierte Anfertigungen; Lieferzeit : 10 Tage.

Otros acabados básicos para el anodizado:

MATE GRATADO Y GRATADO REPULIDO.

Otehr finishes for the basic anodized:

BURNISHED MATT AND RE-PULISHED BURNISHED.

Pour l'anodisé, d'autres finitions de base sont disponibles:

GRATÉ POLI ET MATT BROSSÉ.

Andere Standardanfertigungen in Eloxiert:

MATT PRAEGEPOLIERT UND GLANZ PRAEGEPOLIERT.



Los colores de estos acabados son orientativos y pueden tener diferencias con los originales.



The colours of these finishes are approximate and there may have differences with the originals.



Ces couleurs restent orientatives et il peut y avoir une différence avec les couleurs originales.



Diese Farben sind orientativ und können vom Original abweichen.

ESPECIFICACIONES: SPECIFICATIONS - CARACTÉRISTIQUES - SPEZIFIKATIONEN

INCREMENTO COLOR ESPECIAL: PEDIDOS INFERIORES A 10 MOSQUITERAS

FORFAIT SPECIAL COLOURS : ORDERS LESS THAN 10 INSECT SCREEN. / COULEURS SPÉCIAUX: LES COMMANDES DE MOINS DE 10 MOUSTIQUAIRES.

FARBEN SONDERFARBEN: BESTELLUNGEN UNTER 10 INSEKTENSCHÜTZ

+70 €
NETO

INCREMENTO MADERA ESPECIAL: PEDIDOS INFERIORES A 10 MOSQUITERAS

FORFAIT SPECIAL WOOD: ORDERS LESS THAN 10 INSECT SCREEN. / TON BOIS SPÉCIAUX: LES COMMANDES DE MOINS DE 10 MOUSTIQUAIRES.

FARBEN HOLZ : BESTELLUNGEN UNTER 10 INSEKTENSCHÜTZ

+100 €
NETO



GARANTÍA Y CONDICIONES DE VENTA

GUARANTEE AND SALES CONDITIONS
GSRSENTIE ET CONDITIONS DE VENTE
GARANTIE UND VERKAUFSBEDIN

VALORACIÓN Y CONDICIONES DE LAS INCIDENCIAS:

Las reparaciones deben estar previamente autorizadas y firmadas previamente por los clientes.

Mosquiteras enrollables, fijas, correderas y abatibles a medida:

No se pueden devolver mosquiteras manipuladas por el cliente.

No se admitirán devoluciones con montajes efectuados fuera de las condiciones señaladas en nuestro catálogo.

En caso de devolución, siempre quedara identificable la fecha de fabricación del producto (etiquetas, número de albarán, etc.)

Devolución por golpes, marcas y rasgos.

- Por causa ajena a la empresa no se abonara el valor de la mercancía.
- Por causa imputable a la empresa se abonara el 100% del valor de la mercancía. siempre que venga sin cortar y en embalaje original.

Los portes de las reparaciones dependerán del motivo de la reparación:

- Por causa imputable a la empresa los portes de ida y vuelta correrán a nuestro cargo.
- Por desgaste: El porte de ida y vuelta lo paga el cliente.
- Por otra causa los portes de ida y vuelta correrán a cargo del cliente.

Anulaciones de pedido:

El plazo máximo de anulación de un pedido es de 24h pasado este plazo:

- A) En el caso de material en largo y en color estándar, la anulación no tendrá ningún coste para el cliente.
- B) En caso de material a medida, plisada o de colores especiales, la anulación del pedido supondrá un coste para el cliente, el cual será informado y deberá abonar a la empresa, al haber incurrido la empresa en gastos para la producción del pedido.

Precios:

Los precios cotizados en las tarifas no incluyen IVA o impuesto equivalente.

Condiciones de pago:

Los pagos se realizaran prioritariamente mediante giro bancario. Es necesario que los giros tengan domiciliación bancaria, para emitir devoluciones. Las condiciones de pago especiales serán tratadas específicamente. La propiedad de la mercancía sigue siendo de la empresa hasta que la factura este totalmente abonada.

Impagados:

Cualquier tipo de impago de un efecto, ocasionara automáticamente el bloqueo del pedido y crédito del cliente, haciéndose este cargo de los gastos de devolución, no pudiendo enviarse mas mercancía si hubiese algún saldo pendiente de pago hasta su cancelación.

Garantía de los productos:

La empresa garantiza sus productos durante **dos años** que es lo estipulado por ley, salvo para los desperfectos ocurridos por la corrosión de la perfilería cuando no se ha dañado la superficie. En este caso la garantía seria de **cinco años** (a contar desde la fecha de factura). Cualquier manipulación incorrecta anula la garantía del producto. La garantía de nuestros productos no cubrirá en ningún caso la mano de obra ni desplazamientos.

ESPECIFICACIONES TECNICAS + CARACTERISTICAS GENERALES:

Accesorios Kit mosquitera enrollable:

Descripción: SOOOOUMTME, MUELLE MIXTO 35,5 X 1,3 MOSQ.ENFL Longitud 355 mm ± 5mm, diámetro exterior 14,6mm + 0.- 0,2. NORMA DIN 17223-1: Alambre de acero galvanizado de calidad B-84, y un calibre de 1,3mm. NORMA UNE EN 10270-1: Alambre de acero galvanizado SM-Z, y un calibre de 1.3mm. Resistencia a la tracción: 1900 - 1927N / mm'. Peso Zinc: 114.5 - 149gr/m,. Ensayo funcional / vida útil: 1.500 ciclos continuados en el bastidor y el muelle no presentara deformaciones significativas.

Mosquitera enrollable con guías antiviento:

UNE - EN 13659:2004 Modelo: SOOP42VOOPG. Anchura de 1420mm y altura de 2200 mm. Resistencia a la carga de viento UNE - EN 1932:2001. clase 0. Ensayo: Normas de ensayo: UNE EN 13561:04 apartado 4 UNE EN 1932:01 apartado 9. Mosquitera plegable 2020x1210mm y mosquitera enrollable 2200x 1420mm con guías "antiviento". Condiciones: Temperatura de 22°C y Humedad relativa: 48%.

Tejido Fiberglass:

65% de fibra de vidrio y un 35% de PVC. I 8x16 hilos/pulgada. 0.28±0.03mm. Porcentaje de transición luminosa: Entre 60% y 65%. Clasificación al fuego: Si se le aplica una llama directamente al tejido, este se auto-extingue en menos de 20 segundos (UNE 23727:1990 Clasificación al fuego con materiales). clase M2. Ensayos: Resistencia a la temperatura de variación entre -30°C y 110°C, después de 240 horas el resultado es satisfactorio y mantiene sus características y color. Presión: Resiste 204 Kg por cada 6.5 cm². Tensión: Resiste 36 Kg por cada 6.5cm².

Accesorios PVC:

Están compuestos por: Poliamida, PA6. Semi-cristalino, 60%. Temperatura de fusión de 222°C y densidad de 1.13 g / cm³. Polióxido de Metileno, POM. Un 75% de cristalinidad. Temperatura de fusión de 178°C y densidad del 1.42g/cm³. Buen elástico del POM, autolubricante, resistencia química y baja absorción de agua.

Los Perfiles:

Son aluminio de extrusión I³ fusión con una Aleación 6063-H y un tratamiento térmico T-5.

Los Acabados de nuestros perfiles:

Lacados carta Ral conforme QUALICOAT n° 436. Espesor mínimo 60/80 micas. Imitaciones madera mediante Sistema Decoral pudiendo realizar texturizados. Anodizados de espesor mínimo 15 micas con diferentes acabados.



GARANTÍA Y CONDICIONES DE VENTA

GUARANTEE AND SALES CONDITIONS
GSRSENTIE ET CONDITIONS DE VENTE
GARANTIE UND VERKAUFSBEDIN

EVALUATION AND INCIDENT CONDITIONS:

All reparations have to be previously authorized and signed by the Buyer.

Roller, fixed, sliding and hinged door insect screens:

Insect screens that have been handled by the customer, are not to be returned.

Returns with assemblies made beyond the indicated terms in our catalogue, will not be accepted.

In case of any returned goods, the production date will always remain recognizable, (label, delivery note number, etc)

Goods returned because of bumps, scratches marks:

- Through no fault of the company the good's value will not be paid.
- Through fault of the company the good's value will be paid a 100%. provided that the goods have not been cut and come in their original packaging.

The transport costs of the reparations depend of its reason:

- Through fault of the company the transport costs both ways, will be settled.
- Because of wear: the Buyer will pay the transport one way and the company the other way.
- Because of any other reason, the transport costs both ways will have to be settled by the Buyer.

Order cancellations:

The maximum delay for the cancellation of an order is 24 hours. In case this delay expires:

- A) Dealing with length material in a standard colour, the cancellation will not suppose any cost to the customer.
- B) B) Dealing with measured material, pleated or special colours, the cancellation will suppose a cost for the Buyer about which he will be informed and will have to pay to the company, as the company has been incurring costs because of the order's production.

Prices:

The quoted prices on the price lists do not include VAT, nor suppose any equivalent taxes.

Payment terms:

The payments will first and foremost be done by means of a bank draft. The draft should be foreseen of a bank account number. The special payment terms will be treated specifically. The goods continue to be property of the company until the invoice has been fully settled.

Non-payments:

Any kind of non-payment of an invoice will cause automatically the blocking of the order and the Buyer's credit, this latter being responsible for the return costs. In case there should be any balance to be paid, it will not be possible to send any further goods until its full payment.

Product warranty:

In accordance with the legal stipulations, the company grants a warranty period of two years. In case of corrosion, the warranty period will be extended to 5 years.

Any incorrect handling cancels the product's warranty, and in no case it will cover labour, nor does it travel expenses.

TECHNICAL SPECIFICATIONS + GENERAL CHARACTERISTICS:

Accessories for Roller insect screen:

Description: SOOOUMTME, MIXED SPRING 35.5 X 1.3 MOSQ.ENFL Length 355 mm ± 5mm, outside diameter 14.6mm + 0.- 0.2. DIN 17223-1 STANDARD: Galvanized steel wire of B-84 quality, and a caliber of 1.3mm. UNE EN 10270-1 STANDARD: SM-Z galvanized steel wire, and a caliber of 1.3mm. Tensile strength: 1900 - 1927N / mm². Zinc Weight: 114.5 - 149gr/m. Functional test / useful life: 1,500 continuous cycles in the frame and the spring will not present significant deformations.

Roller insect screen with windscreen guides:

UNE - EN 13659:2004 Model: SOOP42VOOPG. Width 1420mm and height 2200mm. Wind load resistance UNE - EN 1932:2001. class 0. Test: Test standards: UNE EN 13561:04 section 4 UNE EN 1932:01 section 9. Folding mosquito net 2020x1210mm and roll-up mosquito net 2200x1420mm with "windproof" guides. Conditions: Temperature of 22°C and relative humidity: 48%.

Fiberglass mesh:

65% fiberglass and 35% PVC. I 8x16 threads/inch. 0.28±0.03mm. Light transition percentage: Between 60% and 65%. Fire classification: If a flame is applied directly to the fabric, it self-extinguishes in less than 20 seconds (UNE 23727:1990 Fire classification with materials). class M2. Tests: Resistance to temperature variation between -30°C and 110°C, after 240 hours the result is satisfactory and maintains its characteristics and color. Pressure: Resists 204 Kg for every 6.5 cm². Tension: Resists 36 Kg for every 6.5cm².

PVC accessories:

They are composed of: Polyamide, PA6. Semi-crystalline, 60%. Melting temperature of 222°C and density of 1.13 g / cm³. Methylene polyoxide, POM. 75% crystallinity. Melting temperature of 178°C and density of 1.42g/cm³. Good elastic of POM, self-lubricating, chemical resistance and low water absorption.

The profiles:

They are 1st fusion extruded aluminum with an Alloy 6063-H and a T-5 heat treatment.

The Finishes of our profiles:

Ral letter lacquer according to QUALICOAT n° 436. Minimum thickness 60/80 micas. Imitations wood by means of the Decoral System, being able to carry out texturing. Anodized with a minimum thickness of 15 micas with different finishes.



GARANTÍA Y CONDICIONES DE VENTA

GUARANTEE AND SALES CONDITIONS
GSRNTIE ET CONDITIONS DE VENTE
GARANTIE UND VERKAUFSBEDIN

ÉVALUATION ET CONDITIONS DES INCIDENTS:

Les réparations doivent être préalablement autorisée et signée par le client.

Moustiquaires enroulables, fixes, coulissantes et portes battante sur mesure:

Les moustiquaires ne peuvent pas être retournées si elles ont été manipulées par le client

Aucun remboursement ne sera effectué avec certaines manipulations énumérées dans notre catalogue.

En cas de retour, il y aura toujours la date identifiable de fabrication du produit (étiquettes, numéro du bordereau, etc.)

Retour pour coups, marques ou rayures.

- Si la responsabilité n'est pas de l'entreprise le client devra payer la valeur de la marchandise.
- En revanche si l'entreprise est en faute. dans ce cas nous prendrons en charge le 100% de la valeur du matériel. chaque fois que les marchandises soient retournées dans leur emballage d'origine.

Les frais de transport dépendront de la raison de la réparation:

- Si la faute est de l'entreprise nous prendrons en charge les frais de transport d'aller et de retour.
- Pour détérioration : Les frais de retour à l'usine seront pris en charge par le client et ceux d'envoi seront pris en charge par l'entreprise.
- Pour toute autre raison les frais d'aller et de retour seront pris en charge par le client.

Annulation de commande:

Le délai maximum pour l'annulation d'une commande est de 24h, passé cette limite:

A) Dans le cas de matériel en long (barres de 6mts) et couleur standard, l'annulation n'aura aucun coin pour le client.

B) Si le produit. s'avère être du sur-mesure, de la moustiquaire plissée ou du coloris spécial l'annulation de la commande aura un coût pour le client, qui en sera donné et devra payer les frais à la société. ayant encouru des dépenses à l'entreprise pour la production de la commande.

Prix:

Les prix indiqués dans notre grille tarifaire ne comprennent pas la TVA

Modalités de paiement:

Les paiements seront effectués principalement par virement bancaire. Les conditions de paiement spéciales seront traitées individuellement. La propriété des marchandises reste de l'entreprise jusqu'à ce que la facture soit entièrement soldée.

Non-paiement:

Tout non-paiement d'une facture, automatiquement provoque un blocage de la commande et du crédit client ce qui le fait responsable des frais bancaires occasionnés, et la marchandise ne pourra être envoyée jusqu'au paiement complet de la facture.

Garantie:

L'entreprise garantit ses produits pendant deux ans. ce qui est stipulé par la loi. sauf pour détérioration survenue par la corrosion de l'aluminium dans le cas où la surface ne soit pas endommagée alors la garantie serait de cinq ans (à compter de la date de la facture).

Toute manipulation impropre annule la garantie du produit. La garantie de nos produits ne couvre en aucun cas la main d'oeuvre ni les déplacements.

CARACTÉRISTIQUES TECHNIQUES ET CONDITIONS GÉNÉRALES:

Accessoires Kit moustiquaire enroulable:

Description: 50000MUMTME, RESSORT MIXTE 35.5 X 1.3 MOUST. ENR. Longueur 355mm + / - 5mm, diamètre extérieur 14.60 mm + 0. - 0.2 NORME DIN 17223-1: Fil d'acier galvanisé de qualité B-84, et une épaisseur de 1.3 mm. Résistance à la traction: 1900 - 1927N / mm². Poids Zinc 114.5 -149gr/m². Test de fonctionnement / Durée de vie: 1.500 cycles prolongés dans le cadre et le ressort ne présente pas de déformations importantes.

Moustiquaire enroulable avec coulisse anti-vent:

UNE - EN 13659:2004. Modèle: 500P42V00PG. Largeur de 1420mm et 2200mm hauteur. Résistance au vent UNE - EN 1932:2001, Classe O. Essai: Normes tressai: UNE EN 13561:04 paragraphe 4. UNE EN 1932:01 paragraphe 9. Moustiquaire pliable 2020x1210mm et moustiquaire enroulable 2200x1420mm avec coulisses anti-vent. Conditions: Température de 22 ° C et Humidité:48%

Tissu de Fibre de verre:

65% de fibres de verre et 35% de PVC. 18x16 fils/pouce. 0.28 + / -0.03 mm. Pourcentage de transition lumière: Entre 60% et 65%. Classement au feu Si une flamme est appliquée directement sur le tissu, elle s'éteindra dans les 20 secondes (UNE 23727:1990 Classement au feu des matériaux), catégorie M2. Tests: Résistance aux variations de température comprise entre -30 et 110 ° C. après 240 heures le résultat est satisfaisant et conserve ses caractéristiques et sa couleur. Pression: Supporte 20kg par 6.5 cm². Tertiaire Résiste à 36 kg par 6,5 cm².

Accessoires en PVC:

Ils comprennent: Polyamide. PA6. Semi-cristallin, de 60%. Température de fusion de 222 ° C et une densité de 1.13g. Polyoxyde de méthylène. POM. Cristallinité de 75%. Température de fusion 178 ° C et une densité de 1.42 g/cm³. Bonne élasticité du POM. autolubrifiant. résistance chimique et faible absorption d'eau.

Les Profils: Aluminium d'extrusion l'° fusion avec un Alliage 6063-H et un traitement thermique T-5.

Finitions de nos profils: Couleurs Ral conformes QUALICOAT n°436. Épaisseur minimale 60/80 microns. Imitations de bois selon Système Decoral avec la possibilité de faire texture. Épaisseur minimale anodisé 15 microns avec différentes finitions.



GARANTÍA Y CONDICIONES DE VENTA

GUARANTEE AND SALES CONDITIONS
GSRNTIE ET CONDITIONS DE VENTE
GARANTIE UND VERKAUFSBEDIN

BEWERTUNGS- UND STÖRFALLBEDINGUNGEN:

Alle Reparaturen müssen vorher vom Käufer genehmigt und unterschrieben werden.

Roll-, Fest-, Schiebe- und Klapptür-Insektenschutz:

Vom Kunden gehandhabte Insektenschutzgitter werden nicht zurückgenommen.

Rücksendungen mit Baugruppen, die außerhalb der in unserem Katalog angegebenen Fristen hergestellt wurden, werden nicht akzeptiert.

Im Falle von Rücksendungen, das Produktionsdatum bleibt immer erkennbar, (Etikett, Lieferscheinnummer etc.) Rücksendungen wegen

Beulen, Kratzspuren:

Ohne Verschulden des Unternehmens wird der Warenwert nicht bezahlt.

Bei Verschulden des Unternehmers wird der Warenwert zu 100 % erstattet, sofern die Ware ungeschnitten und originalverpackt ist.

Die Transportkosten der Reparationen hängen von ihrem Grund ab:

Bei Verschulden des Unternehmens werden die Transportkosten hin und zurück verrechnet.

Wegen Verschleiß: Der Käufer zahlt den Transport in eine Richtung und die Firma in die andere Richtung.

Aus anderen Gründen gehen die Transportkosten hin und zurück zu Lasten des Käufers.

Auftragsstornierungen:

Die maximale Verzögerung für die Stornierung einer Bestellung beträgt 24 Stunden. Falls diese Frist abläuft:

A) Handelt es sich um Längenmaterial in einer Standardfarbe, verursacht die Stornierung keine Kosten für den Kunden.

B) Umgang mit gemessenem Material, Plisse- oder Sonderfarben, verursacht die Stornierung Kosten für den Käufer, über die er informiert wird und die er an das Unternehmen zahlen muss, da dem Unternehmen durch die Produktion des Auftrags Kosten entstanden sind.

Preise:

Die in den Preislisten angegebenen Preise enthalten keine Mehrwertsteuer und setzen keine entsprechenden Steuern voraus.

Zahlungsbedingungen:

Die Zahlungen erfolgen in erster Linie mittels Bankeinzug. Der Entwurf sollte eine Bankkontonummer vorsehen. Die besonderen

Zahlungsbedingungen werden gesondert behandelt. Bis zur vollständigen Begleichung der Rechnung bleibt die Ware Eigentum des Unternehmens.

Nichtzahlungen:

Jede Art der Nichtzahlung einer Rechnung führt automatisch zur Sperrung der Bestellung und des Kredits des Käufers, wobei letzterer für die Rücksendekosten verantwortlich ist. Falls noch ein Restbetrag zu zahlen ist, können bis zur vollständigen Bezahlung keine weiteren Waren versendet werden.

Produktgarantie:

Das Unternehmen gewährt entsprechend den gesetzlichen Bestimmungen eine Gewährleistungsfrist von zwei Jahren. Bei Korrosion verlängert sich die Gewährleistungsfrist auf 5 Jahre.

Jede unsachgemäße Handhabung erlischt die Produktgarantie und deckt in keinem Fall Arbeits- oder Reisekosten ab.

TECHNISCHE DATEN + ALLGEMEINE EIGENSCHAFTEN:

Zubehör für Insektenschutzrollo:

Beschreibung: SOOOMUMTME, MIXED SPRING 35,5 X 1,3 MOSQ.ENFL Länge 355 mm \pm 5 mm, Außendurchmesser 14,6 mm + 0, - 0,2. DIN 17223-1 STANDARD: Verzinkter Stahldraht der Qualität B-84 und einem Kaliber von 1,3 mm. UNE EN 10270-1 STANDARD: SM-Z verzinkter Stahldraht und ein Kaliber von 1,3 mm. Zugfestigkeit: 1900 - 1927 N / mm². Zinkgewicht: 114,5 - 149gr/m². Funktionstest / Lebensdauer: 1.500

Dauerzyklen im Rahmen und die Feder zeigt keine signifikanten Verformungen.

Insektenschutzrollo mit Frontscheibenführung:

UNE - EN 13659:2004 Modell: SOOP42VOOPG. Breite 1420 mm und Höhe 2200 mm. Windlastwiderstand UNE - EN 1932:2001. Klasse 0. Prüfung:

Prüfnormen: UNE EN 13561:04 Abschnitt 4 UNE EN 1932:01 Abschnitt 9. Faltbares Moskitonetz 2020 x 1210 mm und aufrollbares Moskitonetz 2200 x 1420 mm mit "windfesten" Führungen. Bedingungen: Temperatur von 22°C und relative Feuchtigkeit: 48%.

Glasfasernetz:

65 % Glasfaser und 35 % PVC. I 8x16 Gewinde/Zoll. 0,28 \pm 0,03 mm. Lichtübergangsprozentsatz: Zwischen 60 % und 65 %. Brandklassifizierung: Wenn das Gewebe direkt beflammt wird, verlöscht es in weniger als 20 Sekunden von selbst (UNE 23727:1990 Brandklassifizierung mit Materialien). Klasse M2. Tests: Beständigkeit gegen Temperaturschwankungen zwischen -30°C und 110°C, nach 240 Stunden ist das Ergebnis zufriedenstellend und behält seine Eigenschaften und Farbe bei. Druck: Widersteht 204 kg pro 6,5 cm². Spannung: Widersteht 36 kg pro 6,5 cm².

PVC-Zubehör:

Sie bestehen aus: Polyamid, PA6. Halbkristallin, 60 %. Schmelztemperatur von 222°C und Dichte von 1,13 g/cm³. Methylpolyoxid, POM. 75 % Kristallinität. Schmelztemperatur von 178°C und Dichte von 1,42 g/cm³. Gut elastisch aus POM, selbstschmierend, chemikalienbeständig und geringe Wasseraufnahme.

Die Profile:

Sie sind stranggepresstes Aluminium der ersten Fusion mit einer Legierung 6063-H und einer T-5-Wärmebehandlung.

Die Ausführungen unserer Profile:

RAL-Buchstabenlack gemäß QUALICOAT Nr. 436. Mindestdicke 60/80 Glimmer. Imitation von Holz durch das Decoral System, das Texturen ausführen kann. Eloxiert mit einer Mindestdicke von 15 Glimmer mit verschiedenen Oberflächen.



www.mosquistop.eu



O.H. MOSQUISTOP S.L.

P.I. FUENTE DEL JARRO - C/ VILLA DE BILBAO, 38 C
46988 PATERNA – VALENCIA (ESPAÑA)

TEL: +34 963 219 493

ATENCIONALCLIENTE@OHSISTEMAS.COM